



# ***Challenger MT700 & Fendt 900 MT Undercarriage Installation Instructions***

**For Models:**

**Challenger MT700:** MT738, MT740, MT743

**Fendt 900 MT:** 938 MT, 940 MT, 943 MT

Purchase Date
Serial Number
Model Number
Tractor Model
Dealer

# To The Owner

This manual contains information concerning the installation of the undercarriage. You have purchased dependable, long lasting equipment, but only by proper care and operation can you expect to receive the performance and long service built into our products. Please have all operators read this manual carefully and keep the manual available for ready reference. If you have any questions or concerns, contact Grouser Products.

## Caution:

- Always use caution when working around any equipment.
- Always wear safety glasses.
- Follow tractor manufacturer's safety guidelines when installing this product.
- Use paint where necessary to prevent rust.
- Do not modify or permit anyone else to modify or alter the equipment and its components without first consulting Grouser Products.

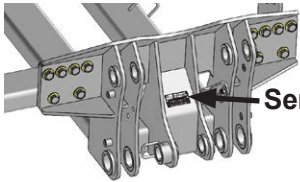

Serial Number Location

## Note:

- When installing hardware, only finger tighten until all hardware is in place.
- A full diagram of the assembly with the full list of parts is on pages 4-5.
- Unstrap and remove any components that are attached for shipping.
- Read all instructions prior to performing installation.



To ensure the safety of those working under and around the machine, apply parking brake, remove key from ignition, and block tires before working on the machine.

## Pre-Installation

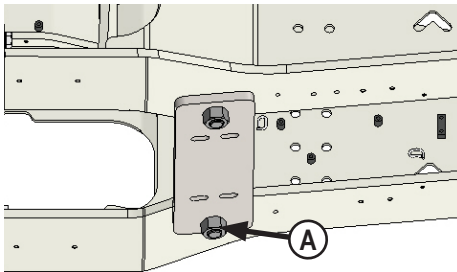

1. Remove weights and weight bracket from front of tractor if necessary.
2. Install rear plate mount with 2 - 1-1/2" x 3-1/2" bolts and 2 - 1-1/2" nuts (A).

## Installation

3. Center undercarriage under tractor.



**Caution:** When lifting undercarriage, watch for potential pinching of hoses or other components to prevent any damage.

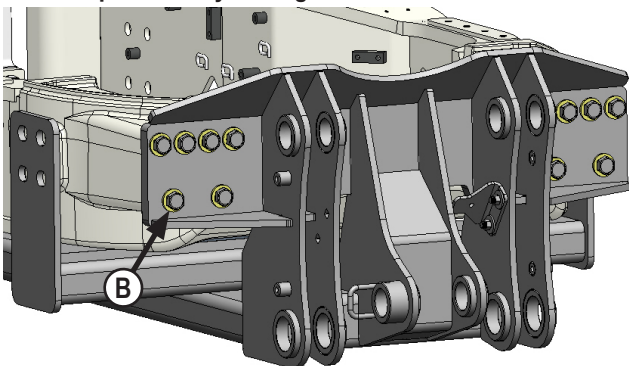

4. Raise undercarriage and attach front of undercarriage to tractor with 12 - 20mm x 70mm bolts and 12 - 3/4" flat washers (B).

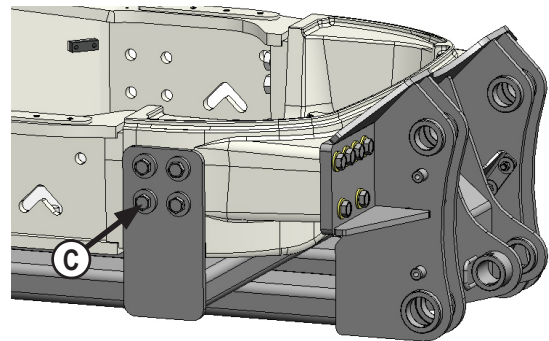

5. Attach side of undercarriage to tractor with 8 - 20mm x 50mm bolts and 8 - 3/4" x 3/8" thick heavy washers (C).

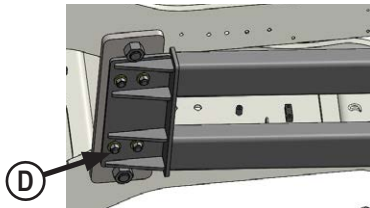

6. Attach rear of undercarriage to rear mount plate from Step # 2 with 4 - 3/4" x 2-1/2" carriage bolts, 4 - 3/4" flat washers and 4 - 3/4" nuts (**D**).
7. Torque rear 1-1/2" bolts (**A**) to 3,200 ft-lbs.
8. Torque front 20mm bolts (**B**) to 432 ft-lbs.
9. Torque side 20mm bolts (**C**) to 432 ft-lbs.
10. Torque rear 3/4" bolts (**D**) to 257 ft-lbs.

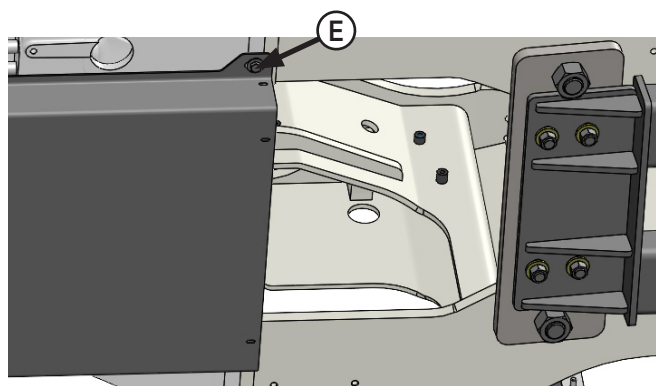

11. Route hoses down undercarriage and through hose loops on undercarriage to back of tractor.
12. Remove 4 bolts where hose channel will be installed.
13. Raise hose channel in place with hoses inside channel and attach with 4 - 12mm x 40mm bolts and 4 - 3/8" fender washers (**E**). Torque 12mm bolts to 105 ft-lbs.
14. Use zip ties in holes in hose channel to secure hoses to hose channel.
15. Protect hoses around sharp corners and moving objects. Use zip ties to secure hoses in place.
16. Plug hoses into open SCV's at rear or tractor.

## Maintenance

1. After first 8 hours of use, re-torque all bolts.
2. Check all fasteners regularly to ensure proper operation of equipment.
3. Inspect all equipment for existing or potential damages every 10 hours or less.

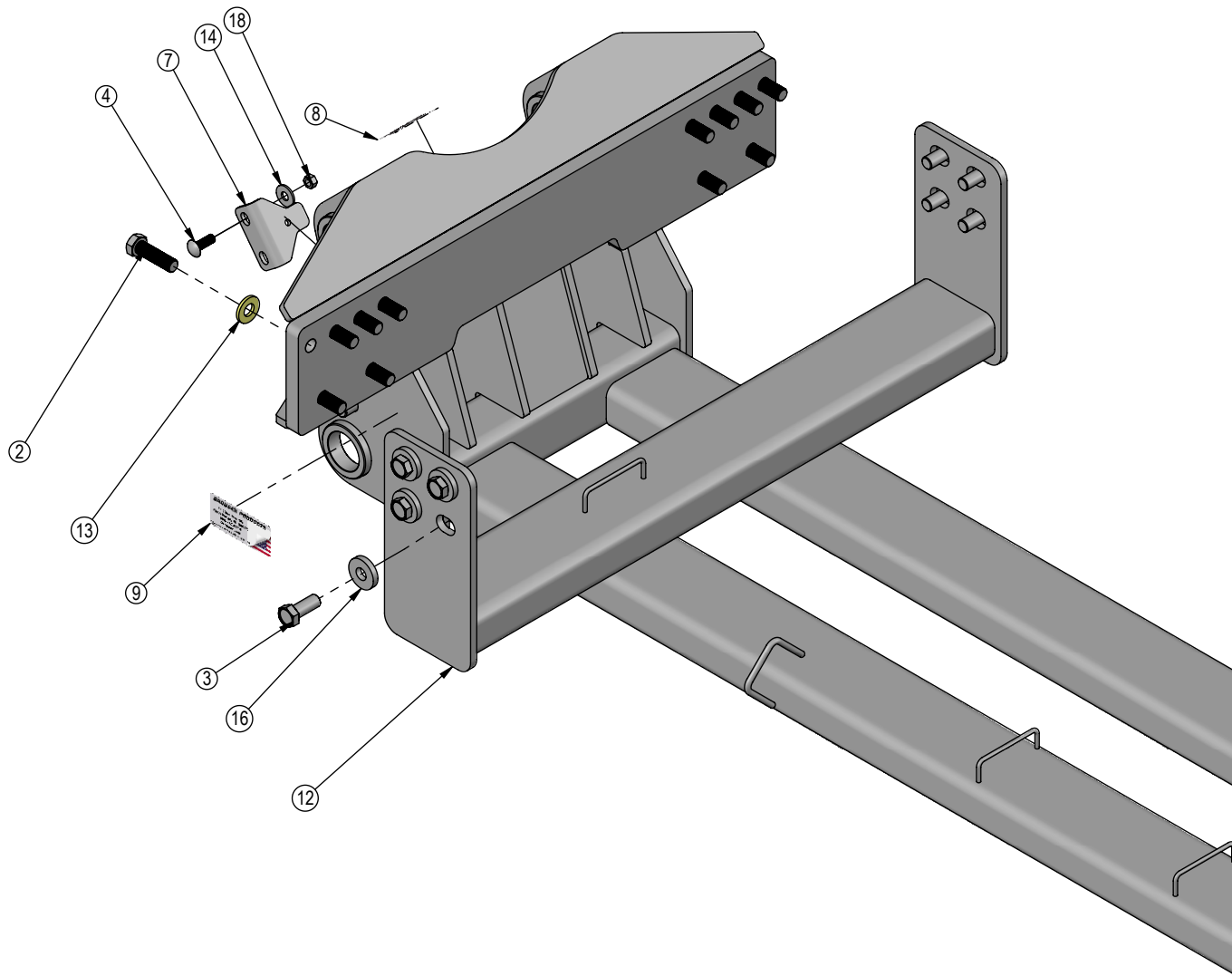

ITEM NO.	QTY.	PART NO.	DESCRIPTION
1	4	16-1217540	12mm x 1.75mm x 40mm Metric Hex Bolt Gr 10.9 Coarse
2	12	16-1876	20mm x 2.5mm x 70mm Hex Bolt Gr 10.9
3	8	16-1878	20mm x 2.5mm x 50mm Hex Bolt Gr 10.9
4	2	16-21126	1/2" x 1-1/2" Carriage Bolt Gr 5 NC
5	4	16-21220	3/4" x 2.50" Carriage Bolt Gr.5
6	2	16-42454	1-1/2" x 3-1/2" Hex Bolt Gr 8 NC
7	1	18-42691	Hose Bracket
8	1	NA	Grouser Dozer Metal Serial Tag
9	1	27-18887	Grouser Name Plate Decal
10	1	44-42655	Plate, Rear Mount
11	1	44-42656	Hose Channel
12	1	54-43155	FH-440 XR Challenger MT700 & Fendt 900 MT U/C
13	16	57-19088	3/4" Hardened HD Flat Washer
14	2	57-20744	1/2" Flat Washer
15	4	57-20792	3/8" Fender Washer
16	8	57-3680	0.75" ID x 2.00" OD x .375" Heavy Washer
17	4	70-20597	3/4" Hex Nut Gr 8 NC
18	2	70-20604	1/2" Center Lock Hex Nut
19	2	70-42458	1-1/2" Hex Nut Gr 8 NC

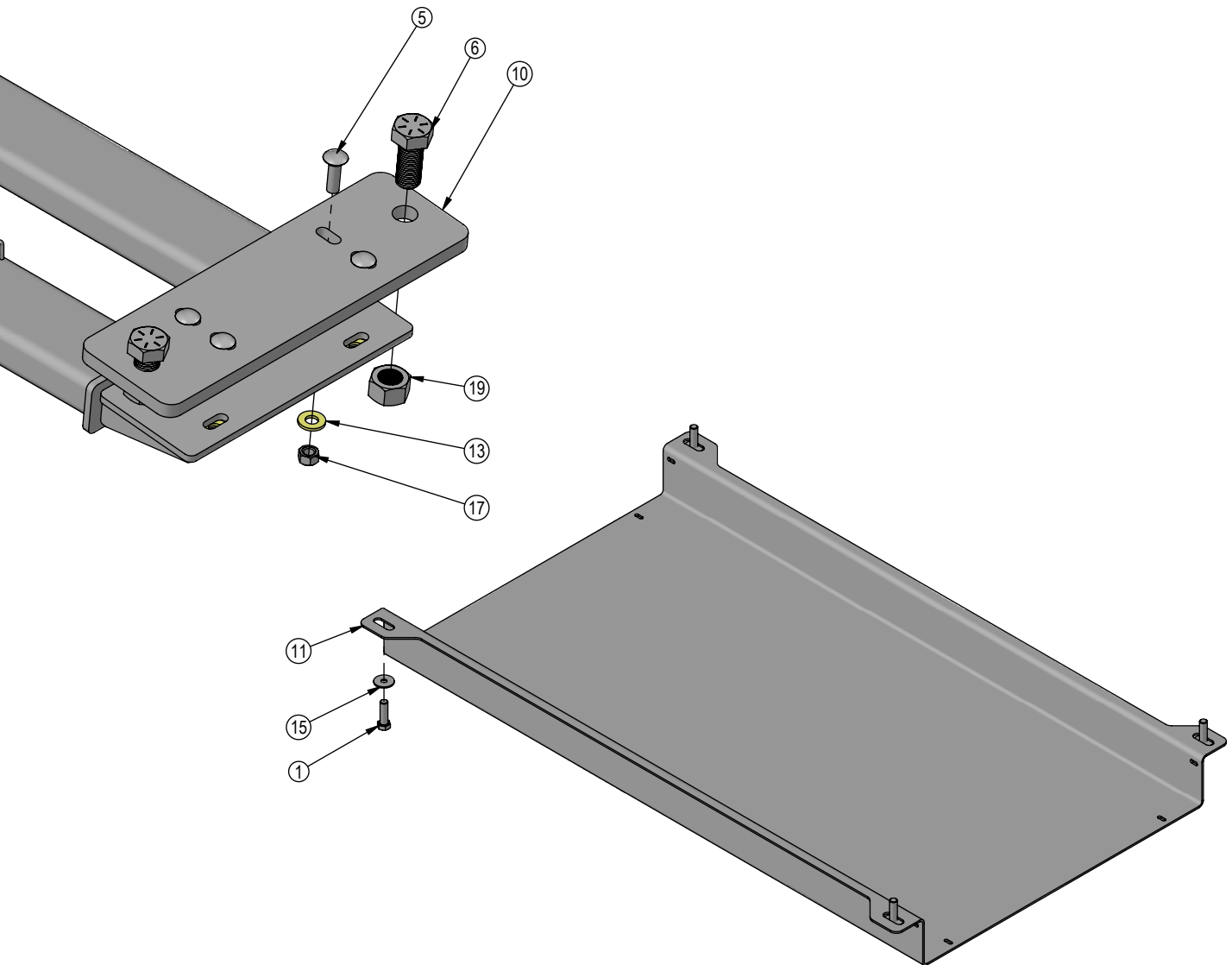

DWG. NO.: 43165-A





# Improvements

---

---

Grouser Products Inc. is continually striving to improve its products. We reserve the right to change prices, specification, or equipment at any time without notice. We also reserve the right to make improvements or changes when it becomes practical and possible to do so without incurring any obligation to make changes or additions to the equipment sold previously.

## Warranty

---

---

Grouser Products warrants to the original purchaser of each item that the product be free from defects in material and workmanship under normal use and service for a period of **two (2) years for Agriculture Series Blades and one (1) year for Heavy Duty Series from date of original retail delivery.**

### **The obligation of the consumer under this warranty:**

1. To read the operators manual and to operate, lubricate, maintain and store equipment in accordance with the instructions listed in the operators manual.
2. To inspect equipment and if any part needs repair or replacement when continued use would cause damage or wear to other parts or safety.
3. All equipment or parts claimed to be defective in material or workmanship must be made available for inspection at the place of business of a dealer authorized to handle the equipment covered by this warranty, or, upon request by Grouser Products, shipped to the Grouser Products factory in West Fargo, North Dakota.

### **The obligation of the dealer under this warranty:**

1. Complete warranty registration form and submit within 30 days of sale.
2. Contact Grouser Products for authorization prior to performing any warranty repairs or part replacement.
3. Complete warranty request form and submit with photos and supporting documentation.

### **The obligation of Grouser Products under this warranty:**

1. Repair or replace, any equipment or parts, in the judgment of Grouser Products to be defective in material or workmanship.
2. Grouser Products will cover the cost of parts and ground shipping at dealer invoice only.
3. Grouser Products shall have no obligation to bear the cost of labor or transportation in connection with replacement or repair of any such defective parts.

### **This warranty does not cover:**

1. Depreciation or damage caused by normal wear, accident, improper assembly, improper adjustments.
2. Improper maintenance including lack of proper lubrication, or improper use. Including loose bolts, nuts, or fitting due to over tightening or vibration after 20 hours of operation.
3. Repairs or alterations without authorization from a Grouser Products representative.
4. Grouser Products shall have no liability if the equipment has been altered or reworked without the written authorization of Grouser Products.

Grouser Products' parts, which are furnished under this warranty and properly installed, shall be warranted to the same extent as the original parts under this warranty if, and only if, such parts are found to be defective within the original warranty period covering the original equipment.

**NO EMPLOYEE OR REPRESENTATIVE OF GROUSER PRODUCTS IS AUTHORIZED TO CHANGE THE WARRANTY IN ANY WAY OR GRANT ANY OTHER WARRANTY.**

## Contact Us

---

---

As always, if you have any questions about your system or other products made by Grouser, feel free to contact us.



755 2nd Ave NW - West Fargo, ND 58078  
+1 701-282-7710 | [info@grouser.com](mailto:info@grouser.com)  
[www.grouser.com](http://www.grouser.com)