



JOHN DEERE 9R IT4

Ag Pro Undercarriage

Installation Instructions

For Models:

John Deere 9R IT4: 9360R, 9410R, 9460R, 9510R, 9560R

Model Year 2012-2014

Purchase Date
Serial Number
Model Number
Tractor Model
Dealer

To The Owner

This manual contains information concerning the installation of the undercarriage. You have purchased dependable, long lasting equipment, but only by proper care and operation can you expect to receive the performance and long service built into our products. Please have all operators read this manual carefully and keep the manual available for ready reference. If you have any questions or concerns, contact Grouser Products.

Caution:

- Always use caution when working around any equipment.
- Always wear safety glasses.
- Follow tractor manufacturer's safety guidelines when installing this product.
- Use paint where necessary to prevent rust.
- Do not modify or permit anyone else to modify or alter the equipment and its components without first consulting Grouser Products.

Note:

- When installing hardware, only finger tighten until all hardware is in place.
- A full diagram of the assembly with the full list of parts is on pages 6-7.
- Unstrap and remove any components that are attached for shipping.
- Read all instructions prior to performing installation.
- Tractor frame not shown in some diagrams for clarity.

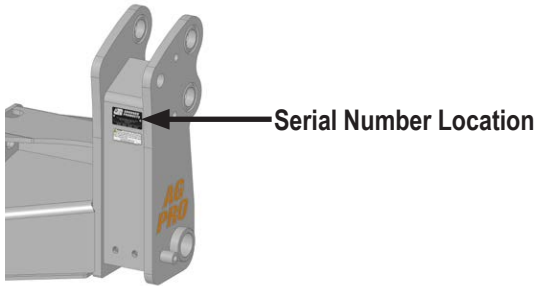

 To ensure the safety of those working under and around the machine, apply parking brake, remove key from ignition, and block tires before working on the machine.

Pre-Installation

1. If applicable, remove front weights, weight bracket, toolbox, and front axle brace from front of tractor.

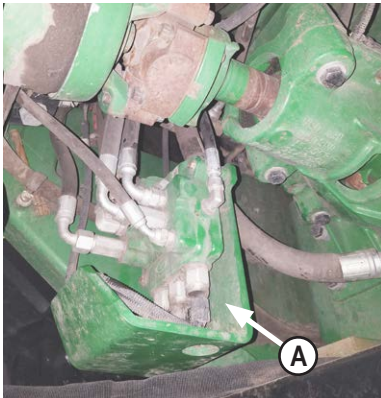

2. Locate steering hydraulics behind right axle and remove valve bracket bolts and move valve and bracket out of the way to gain access to 3 holes (A).

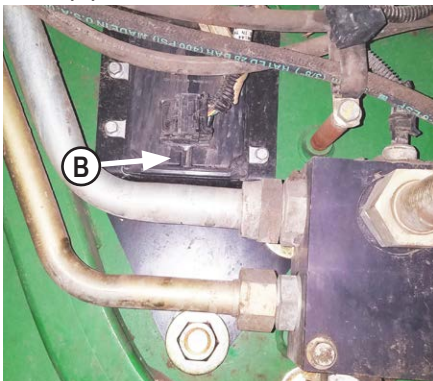

3. If applicable, remove hardware from drive shaft sensor controller (B) on left inside frame of tractor. The sensor will be reattached with new hardware in Step #12-13.

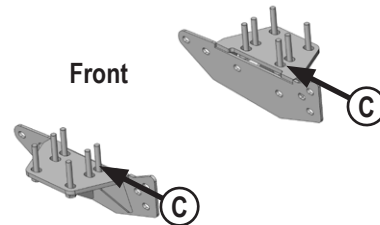

4. Attach axle brackets to front axle vertical holes with 12 - 24mm x 150mm bolts and 12 - 1.05" ID washers (C).
5. Push brackets outwards away from center of tractor to make room for installing undercarriage.

NOTE: Some tractors only have 4 holes in axle. The installation instructions are still compatible, but only use 4 bolts and washers instead of 6 on each side for Step #4.

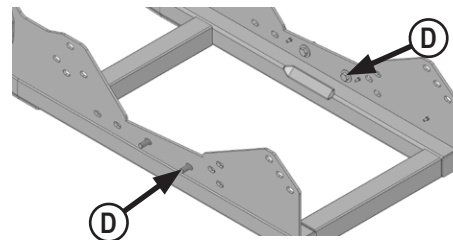

6. Install 4 - 7/8" x 2-1/2" bolts and 4 - 7/8" heavy duty flat washers from inside of undercarriage into 2 center bolting locations for the axle brackets (D).

Installation

7. Position undercarriage under tractor, center on frame of tractor. Lift undercarriage until holes of undercarriage line up with holes in side of tractor frame.



NOTE: When lifting undercarriage, watch bolts that were installed in Step #6 so they do not hit installed axle brackets on tractor and watch for any potential pinching of hoses or any other components to prevent any damage.

NOTE: Add shims between undercarriage and tractor frame to reduce any gap if necessary. Use shims until there is a gap of 1/16" or less on front. See attached diagram for proper location and orientation of each shim. Do Not put all of shims on one side of undercarriage.

NOTE: For Steps #8-15, only a few bolts will be installed to hold shims in place until the correct amount of shims are installed on each side.

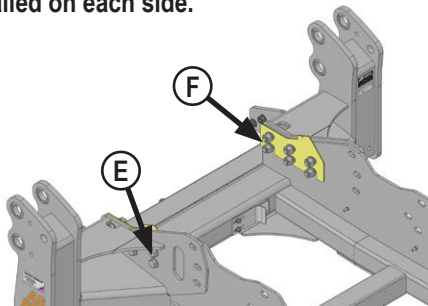

8. Install 2 - 7/8" x 3" bolts and 2 - 7/8" hardened flat washers on left side through front holes on undercarriage, shim, and tractor frame (E).

9. After 2 bolts are through tractor frame, attach with 2 - 7/8" hardened washers and 2 - 7/8" nuts (F).

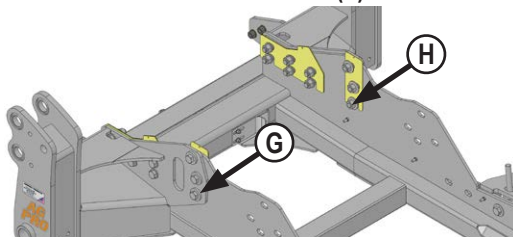

10. Install 2 - 7/8" x 3" bolts and 2 - 7/8" ID thick washers on left side through 2nd set of holes on undercarriage, shim, and tractor frame (G).

11. After 2 bolts are through tractor frame, attach with 2 - 7/8" heavy duty flat washers and 2 - 7/8" nuts (H).

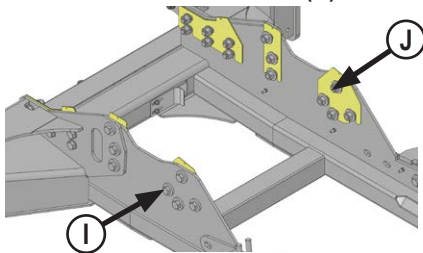

12. Install 2 - 7/8" x 2-1/2" bolts and 2 - 7/8" ID thick washers on left side through 3rd set of holes on undercarriage, shim, and tractor frame (I).

13. After 2 bolts are through tractor frame, attach the controller from Step #3 in the original location with 2 - 7/8" heavy duty flat washers and 2 - 7/8" nuts (J).

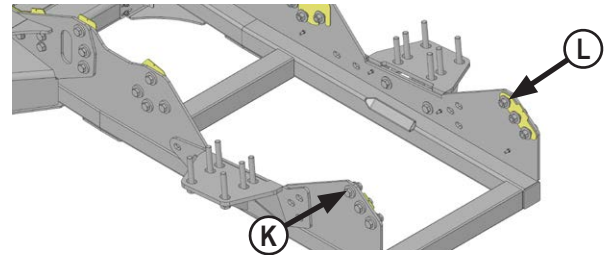

14. Install 2 - 7/8" x 2-1/2" bolts and 2 - 7/8" ID thick washers on left side through last set of holes on undercarriage, shim, and tractor frame (K).

15. After 2 bolts are through tractor frame, attach with 2 - 7/8" heavy duty flat washers and 6 - 7/8" nuts (L).

16. Tighten hardware on the left side of undercarriage until snug. If necessary, add more shims on the right side until a gap of 1/16" or less is on the right side.

17. Follow Steps #8-16 for the right side.

18. After correct number of shims are installed on each side, follow steps #8-15 to install remaining hardware for each set of holes on the undercarriage.

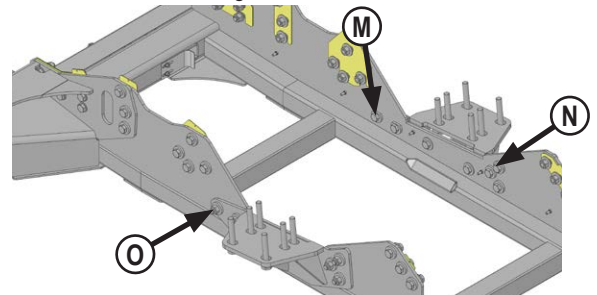

19. Slide axle brackets toward center of tractor.

20. Install 4 - 7/8" x 3" bolts and 4 - 7/8" clipped washers from inside in front 4 slots on axle brackets (M). Turn the washers until the flat edge is facing up.

21. Install 6 - 7/8" x 3" bolts and 6 - 7/8" ID thick washers from inside in rear 6 slots on axle brackets (N).

22. Attach axle brackets to undercarriage with 14 - 7/8" ID thick washers and 14 - 7/8" nuts (O).

23. Tighten vertical 24mm bolts on the axle brackets (C).

24. Torque all 7/8" undercarriage bolts (E-O) on each side of tractor frame to 600 ft-lbs.

25. Reattach the valve bracket with the original hardware that was moved out of the way in Step #2.

26. Torque vertical 24mm bolts (C) to 909 ft-lbs.

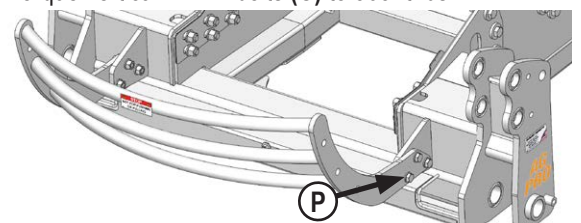

27. Install the grill guard to front of undercarriage with 6 - 3/4" x 2-1/2" bolts, 12 - 3/4" flat washers and 6 - 3/4" nuts (P).

28. Torque 3/4" bolts (P) to 257 ft-lbs.

NOTE: If applicable, refer to Page 5 to attach the tow cable bracket.

Hose Routing

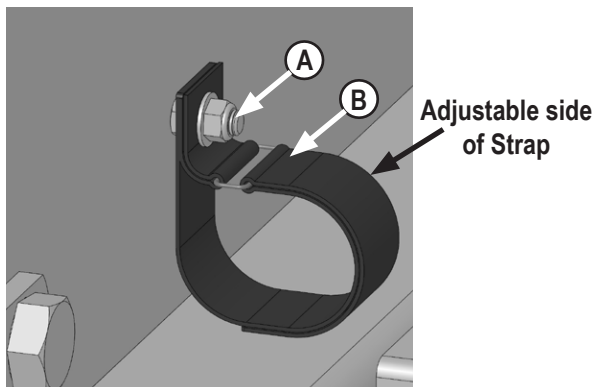

1. Attach a velcro hose strap on every bolt along undercarriage with a 3/8" flange nyloc nut (A). Assemble strap with the metal loop on bottom side as shown (B). Keep straps open.

NOTE: Orientation of velcro strap is important and is shown in photo.

NOTE: Quantity of hoses is dependent on which blade system is being used.

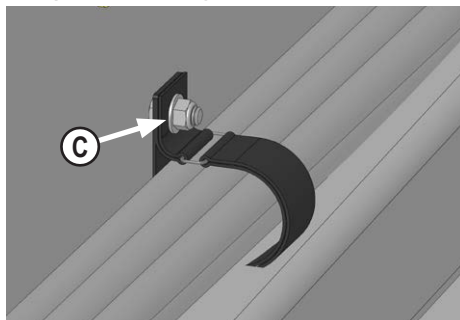

2. Route hoses along undercarriage tubes and secure with velcro straps (C).

NOTE: While grouping hoses together, do not cross hoses over each.

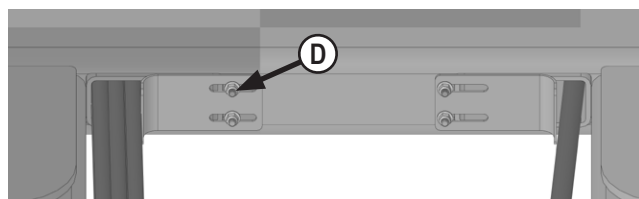

3. Attach hose cover plates to undercarriage with 4 - 3/8" flange nyloc nuts (D). Slide plates until snug against hoses and tighten nuts.

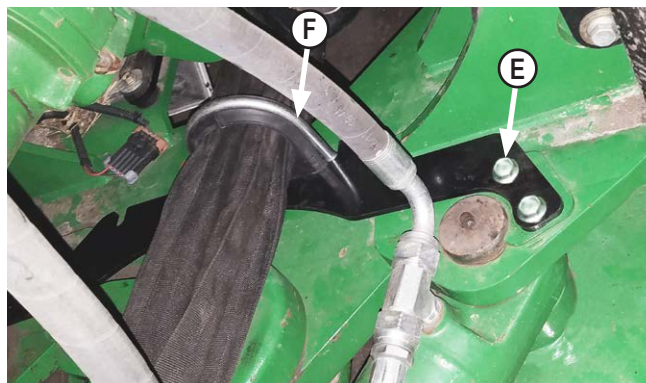

4. At pivot area of tractor, remove bolts from pin retaining plates. Install hose routing plate over pin retaining plates with new 12mm flange bolts. Torque 12mm bolts to 105 ft-lbs (E).

5. Route hoses through the hose loops on undercarriage. Continue through tractor frame and a u-bolt. Attach u-bolt to hose routing plate (F).

NOTE: When installing u-bolts, the rubber inserts can be pulled apart to wrap around the hoses. Verify that the rubber inserts are in place before tightening the u-bolts.

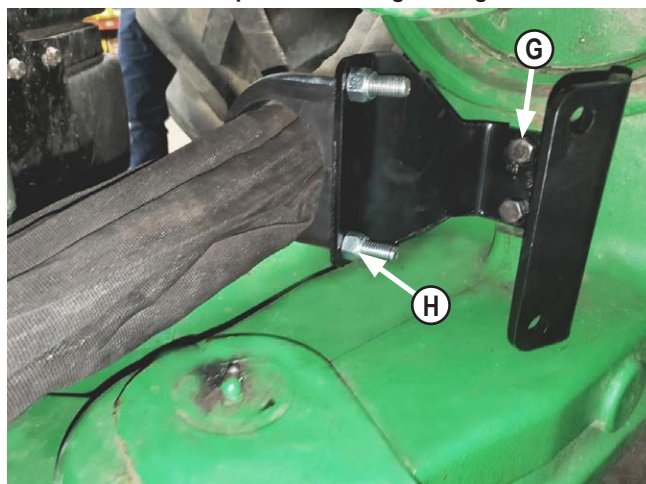

6. Attach hose routing plate to tractor frame below the PTO with 2 - 10mm x 25mm bolts (G).

7. Route hoses through a u-bolt and attach u-bolt to the hose routing plate (H).

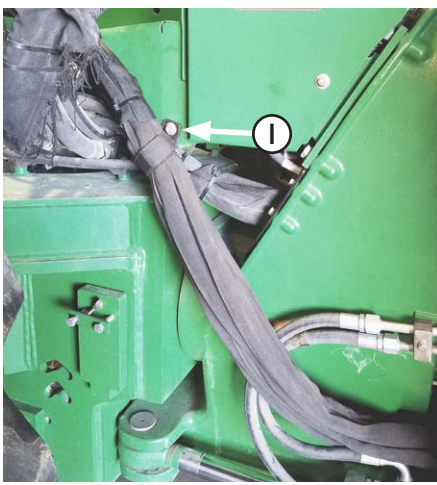

8. Route hoses up along right side of rear frame and group hoses together with a velcro strap. Attach velcro strap to the PTO shield with original hardware (I).

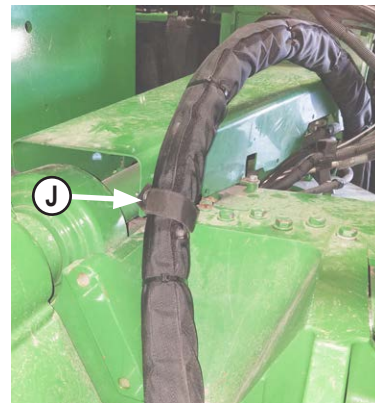

9. Use a velcro strap to group hoses together and attach to the PTO shield with 1 - 5/16" x 1" bolt and 1 - 5/16" flat washer (J).

NOTE: With an adjustable blade, repeat steps #5-9 on left side of tractor for adjustable blade hydraulic hoses. For Step #9, route hoses over the PTO shield and use a 2nd velcro strap to secure adjustable blade hydraulic hoses in the same location as the strap and hoses from the right side.

10. Plug hoses into open SCV's at back of tractor.

11. Make sure there is some slack in hoses. Turn and oscillate tractor to verify there is enough slack. If hoses are too loose, they may catch on moving parts or debris.

NOTE: The quantity of hoses may vary depending on blade system.

Special Note:

John Deere 9R tractors (non scraper versions) can experience a condition that will cause a cavitation or squealing in the hydraulic pump. The symptoms could be a chatter when operator raises their blade, the blade wanting to ride up the pile, or a delay in lift.

If you experience these conditions, please refer to John Deere Accumulator Kit RE337241.

Maintenance

1. After first 8 hours of use, re-torque all bolts.
2. Check all fasteners regularly to ensure proper operation of equipment.
3. Inspect all equipment for existing or potential damages every 10 hours or less.

Tow Cable Support Bracket Assembly

NOTE: Kit (PN: 41788-A) is required if tractor has a tow cable.

1. Attach the tow cable bracket and the tow cable as shown below. Torque the 7/8" bolts to 600 ft-lbs.

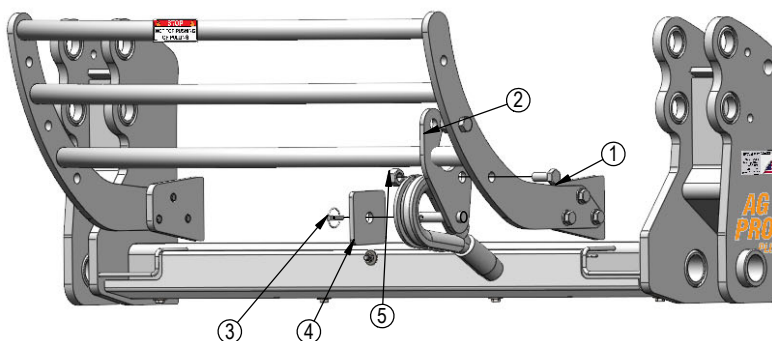

Tow Cable Support Bracket Assy - 18-41788-A			
ITEM NO.	QTY.	PART NO.	DESCRIPTION
1	2	16-20538	7/8" x 2" Hex Bolt Gr 8 NC
2	1	18-41788	Tow Cable Bracket
3	1	43-16764	7/16" x 1-3/4" Lynch Pin
4	1	44-15585	Plate
5	2	70-20598	7/8" Hex Nut - Gr 8 NC

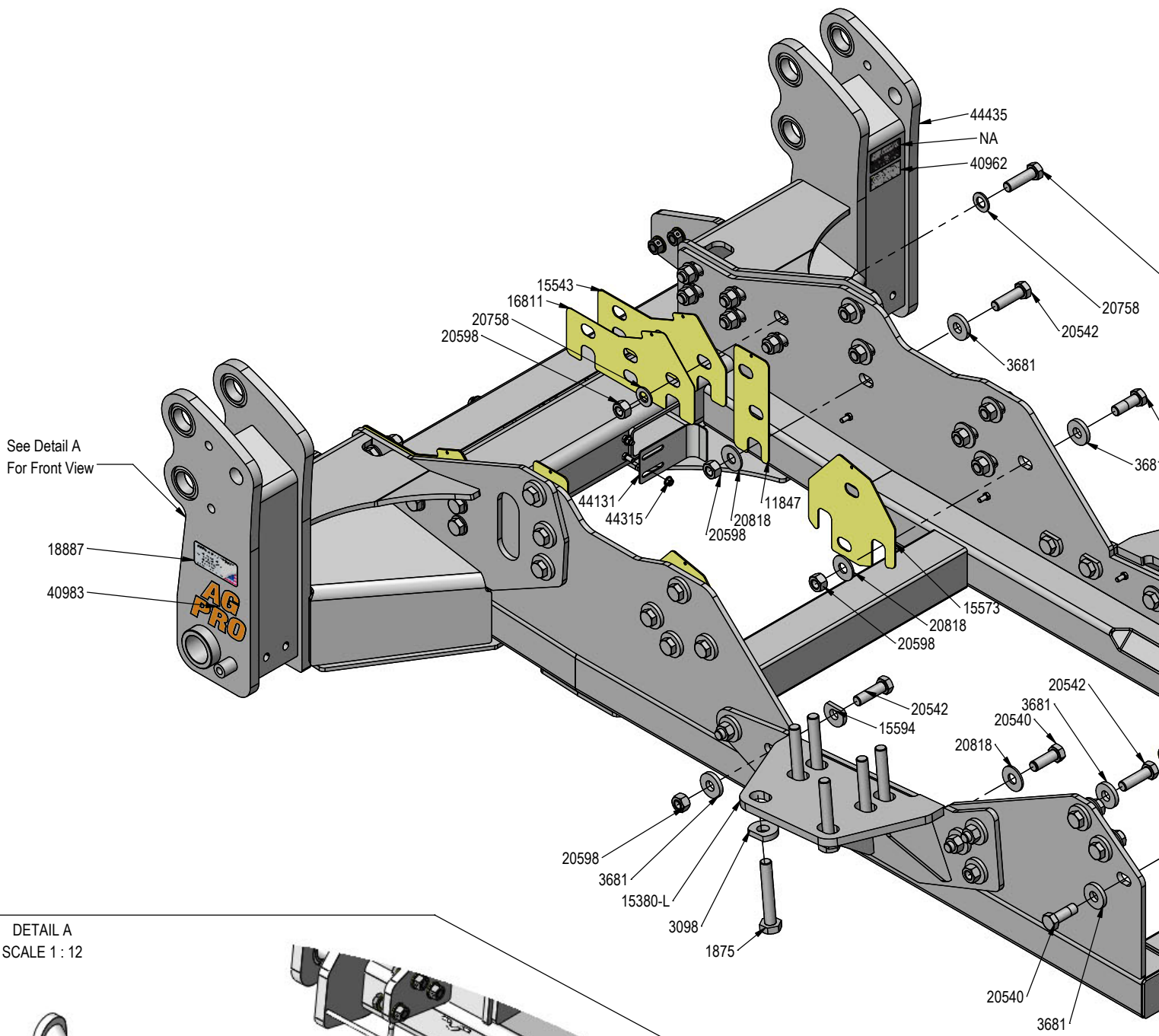

DETAIL A
SCALE 1 : 12

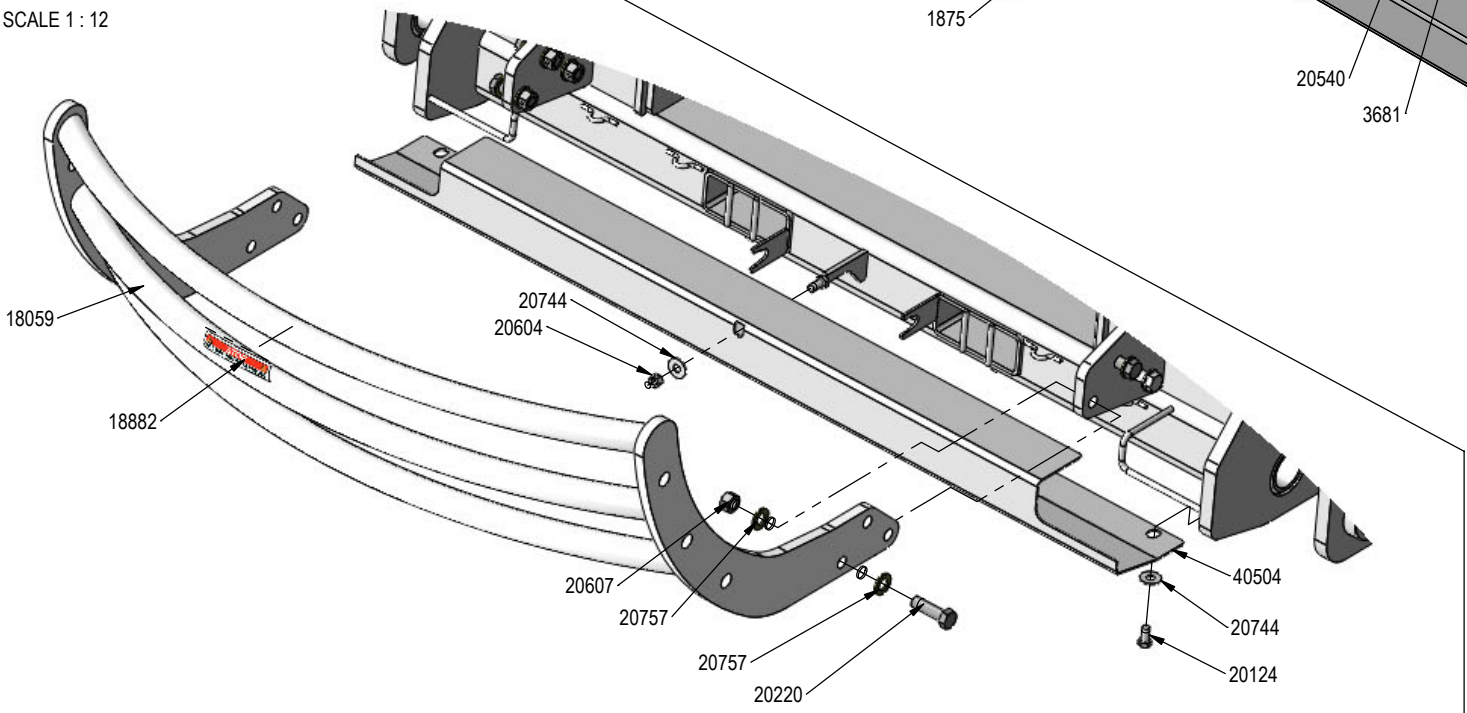

20542

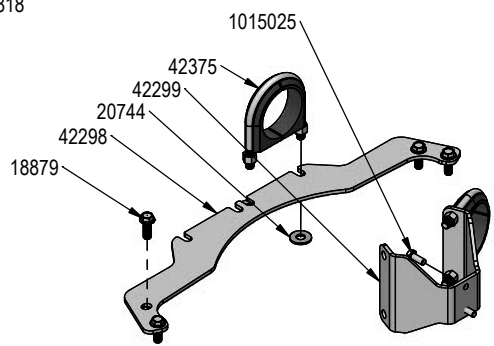
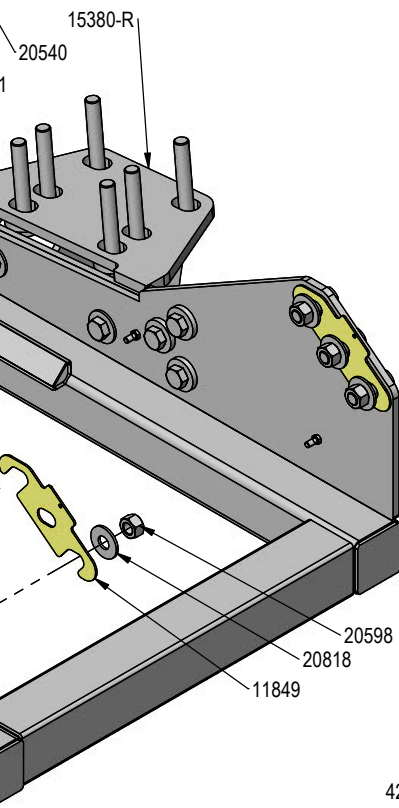

QTY.	PART NO.	DESCRIPTION
12	1875	24mm x 3.00mm x 150mm Hex Bolt
12	3098	1.05" ID x 2.50" OD - JD Axle Mount Washer
40	3681	7/8" ID x 2-1/4" OD x .375" Heavy Washer
2	11847	Plate, Mid-Front
2	11849	Plate, Rear
1	15380-L	Bracket, Axle Weld
1	15380-R	Bracket, Axle Weld
2	15543	Plate,Front
2	15573	Plate,Mid-Rear
4	15594	7/8" ID x 2-1/4" OD x .375" Heavy Washer CZ Plated
2	16811	Plate,Front
2	16899-X *	Heavy Duty Velcro Strap
1	18059	Grill Guard Weld
4	18879	12mm x 1.75mm x 35mm Serrated Flange Bolt 10.9 CZ
1	18882	Not For Pushing or Pulling Decal
1	18887	Grouser Name Plate Decal - Made in USA
4	20124	1/2" X 1" Hex Bolt Gr 5 NC CZ
6	20220	3/4" X 2-1/2" Hex Bolt Gr 5 NC CZ
18	20540	7/8" X 2-1/2" Hex Bolt Gr 8 NC YZ
28	20542	7/8" X 3" Hex Bolt Gr 8 NC YZ
46	20598	7/8" Hex Nut Gr 8 NC CZ
1	20604	1/2" Hex Center Lock Nut Gr 5 NC CZ
6	20607	3/4" Hex Center Lock Nut Gr 5 NC CZ
7	20744	1/2" Flat Washer CZ
12	20757	3/4" SAE Hardened Flat Washer - 1-1/2" OD
24	20758	7/8" SAE Hardened Flat Washer - 1-3/4" OD
24	20818	7/8" Flat Washer Heavy Duty Gr 8 (USS) YZ
1	40504	Plate, Cover
1	40962	Warning Prop 65 Decal
2	40983	Ag Pro
1	42298	Plate
1	42299	Bracket, Hose Routing
2	42375	Cushioned U-Bolt with Nuts
2	44131	Plate, Hose Cover
4	44315	3/8" Nyloc Flange Nut Gr N5 NC
1	44435	Undercarriage Weld
2	1015025	10mm x 1.50mm x 25mm Metric Hex Bolt Gr 10.9 Coarse
1	NA	Serial Number Tag

Note: For Item 42375 and 16899-X, use quantity of 4 when used with an adjustable blade.
* Parts Not Shown

Improvements

Grouser Products Inc. is continually striving to improve its products. We reserve the right to change prices, specification, or equipment at any time without notice. We also reserve the right to make improvements or changes when it becomes practical and possible to do so without incurring any obligation to make changes or additions to the equipment sold previously.

Warranty

Grouser Products warrants to the original purchaser of each item that the product be free from defects in material and workmanship under normal use and service for a period of **two (2) years for Agriculture Series Blades and one (1) year for Heavy Duty Series from date of original retail delivery.**

The obligation of the consumer under this warranty:

1. To read the operators manual and to operate, lubricate, maintain and store equipment in accordance with the instructions listed in the operators manual.
2. To inspect equipment and if any part needs repair or replacement when continued use would cause damage or wear to other parts or safety.
3. All equipment or parts claimed to be defective in material or workmanship must be made available for inspection at the place of business of a dealer authorized to handle the equipment covered by this warranty, or, upon request by Grouser Products, shipped to the Grouser Products factory in West Fargo, North Dakota.

The obligation of the dealer under this warranty:

1. Complete warranty registration form and submit within 30 days of sale.
2. Contact Grouser Products for authorization prior to performing any warranty repairs or part replacement.
3. Complete warranty request form and submit with photos and supporting documentation.

The obligation of Grouser Products under this warranty:

1. Repair or replace, any equipment or parts, in the judgment of Grouser Products to be defective in material or workmanship.
2. Grouser Products will cover the cost of parts and ground shipping at dealer invoice only.
3. Grouser Products shall have no obligation to bear the cost of labor or transportation in connection with replacement or repair of any such defective parts.

This warranty does not cover:

1. Depreciation or damage caused by normal wear, accident, improper assembly, improper adjustments.
2. Improper maintenance including lack of proper lubrication, or improper use. Including loose bolts, nuts, or fitting due to over tightening or vibration after 20 hours of operation.
3. Repairs or alterations without authorization from a Grouser Products representative.
4. Grouser Products shall have no liability if the equipment has been altered or reworked without the written authorization of Grouser Products.

Grouser Products' parts, which are furnished under this warranty and properly installed, shall be warranted to the same extent as the original parts under this warranty if, and only if, such parts are found to be defective within the original warranty period covering the original equipment.

NO EMPLOYEE OR REPRESENTATIVE OF GROUSER PRODUCTS IS AUTHORIZED TO CHANGE THE WARRANTY IN ANY WAY OR GRANT ANY OTHER WARRANTY.

Contact Us

As always, if you have any questions about your system or other products made by Grouser, feel free to contact us.



755 2nd Ave NW - West Fargo, ND 58078
+1 701-282-7710 | info@grouser.com
www.grouser.com