



Case STX & New Holland TJ/T9000 Ag Pro Undercarriage Installation Instructions

For Models:

Case STX Wheeled: 375, 380, 385, 425, 430, 435, 440, 450, 500

Case STX Welded Yoke: 375, 425, 440, 450, 500 (JEE0106700 and Before)

Case STX Cast Yoke: 375, 380, 385, 425, 430, 435, 440, 450, 500 (JEE0106701 and After)

New Holland: TJ375, TJ380, TJ425, TJ430, TJ440, TJ450, TJ500, T9030, T9040

Purchase Date
Serial Number
Model Number
Tractor Model
Dealer

To The Owner

This manual contains information concerning the installation of the undercarriage. You have purchased dependable, long lasting equipment, but only by proper care and operation can you expect to receive the performance and long service built into our products. Please have all operators read this manual carefully and keep the manual available for ready reference. If you have any questions or concerns, contact Grouser Products.

Caution:

- Always use caution when working around any equipment.
- Always wear safety glasses.
- Follow tractor manufacturer's safety guidelines when installing this product.
- Use paint where necessary to prevent rust.
- Do not modify or permit anyone else to modify or alter the equipment and its components without first consulting Grouser Products.



Serial Number Location

Note:

- When installing hardware, only finger tighten until all hardware is in place.
- A full diagram of the assembly with the full list of parts is on pages 6-11.
- Unstrap and remove any components that are attached for shipping.
- Read all instructions prior to performing installation.



To ensure the safety of those working under and around the machine, apply parking brake, and remove key from ignition before working on the machine.

Pre-Installation

1. If applicable, remove front weights, weight bracket, tow cable, tow cable holder, and toolboxes from front of tractor.

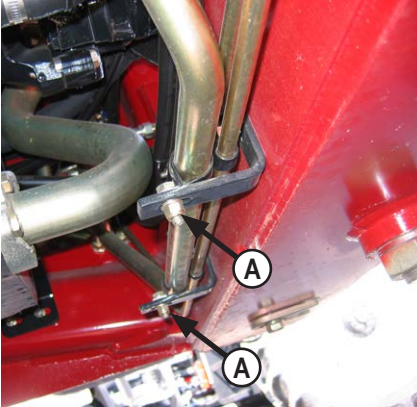

2. Remove the 2 bolts holding the steel line at the center pivot of the tractor (A). Reinstall the bolts from the opposite direction (head down) to allow more clearance for the undercarriage.

Wheeled Installation Only:

3. Continue installation with Step #11.

Quad - Welded Yoke Installation Only:

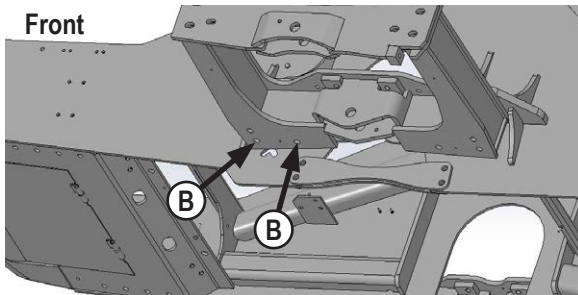

4. Remove front 2 - 24mm bolts from bottom of axle closest to center on both sides (B). Discard bolts.

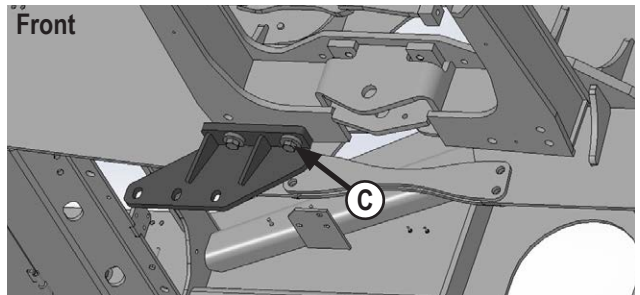

5. Attach each side bracket to bottom of front axle with 2 - 24mm x 300mm bolts and 2 - 1.05" ID (clipped) washers (C).

6. Continue installation with Step #11.

Quad - Cast Yoke Installation Only:

7. Remove 2 - 24mm bolts and spacers from front axle on both sides. Discard spacers.

8. Dip previously removed 24mm bolts in W30 oil.

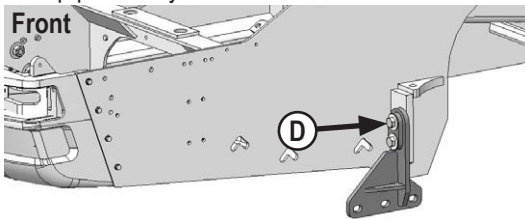

9. Attach each side bracket to front axle with 2 - 24mm bolts from Step #7 and 2 - 1" flat washers (D).

10. Continue installation with Step #11.

Undercarriage Installation

11. Position and center undercarriage under tractor. Lift undercarriage until it is within 3/4" of touching tractor frame.

NOTE: When lifting undercarriage, watch for any potential pinching of hoses or any other components to prevent any damage.

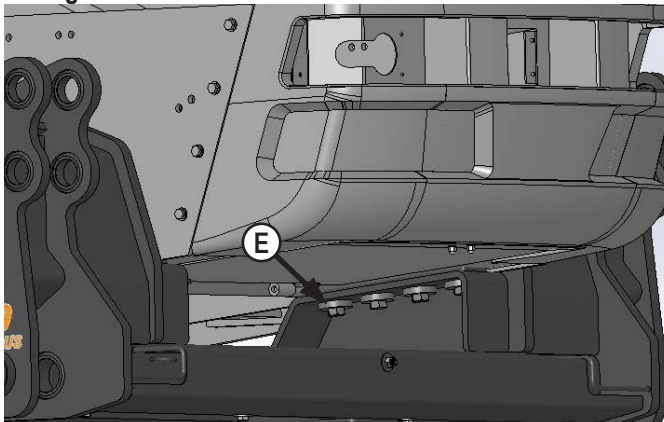

12. Install 8 - 20mm x 90mm bolts and 8 - 0.88" ID heavy washers in vertical slots at front of undercarriage (E). Turn in until washers make contact with undercarriage.

13. Lift rear of undercarriage until two rear mounting ears touch up against tractor's cross member.

NOTE: Be sure that vertical push plates are firmly against cross member (F).

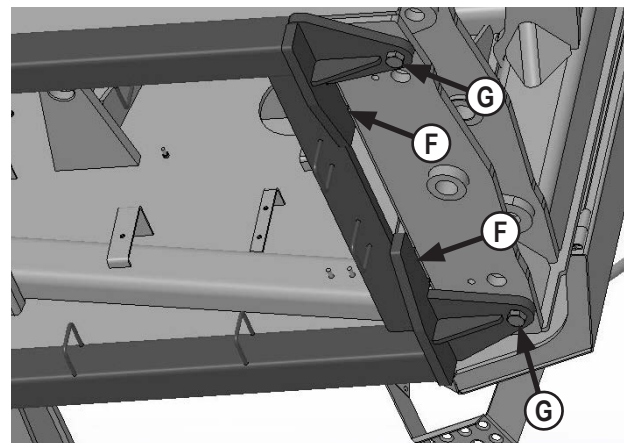

14. Using two holes in rear ears as guides, drill 2 - 1" holes through cross member and install 2 - 1" x 3" bolts and 2 - 1" nuts (G).

Wheeled Installation Only:

15. Torque rear 1" bolts to 903 ft-lbs.
16. Torque front vertical 20mm bolts to 432 ft-lbs.
17. Continue installation with Step #30.

Quad - Welded Yoke Installation Only:

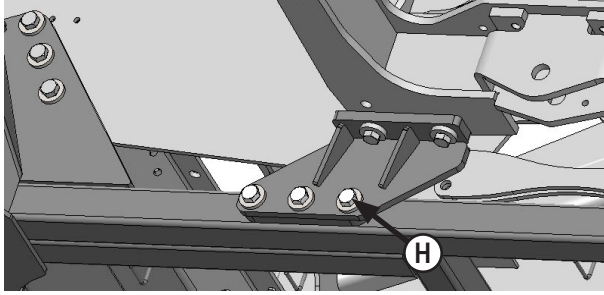

18. Attach side brackets to sides of undercarriage with 6 - 1" x 2-1/2" bolts and 6 - 1" ID heavy washers (H).
19. Torque rear 1" bolts to 903 ft-lbs.
20. Torque vertical 24mm axle bolts to 909 ft-lbs.
21. Torque front vertical 20mm bolts to 432 ft-lbs.
22. Torque side bracket 1" bolts to 903 ft-lbs.
23. Continue installation with Step #30.

Quad - Cast Yoke Installation Only:

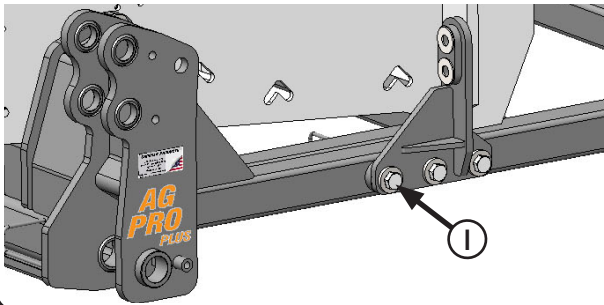

24. Attach side brackets to sides of undercarriage with 6 - 1" x 2-1/2" bolts and 6 - 1" ID heavy washers (I).
25. Torque rear 1" bolts to 903 ft-lbs.
26. Torque 24mm axle bolts to 555 ft-lbs.
27. Torque front vertical 20mm bolts to 432 ft-lbs.
28. Torque side bracket 1" bolts to 903 ft-lbs.
29. Continue installation with Step #30.

Wheeled and Quad Installation:

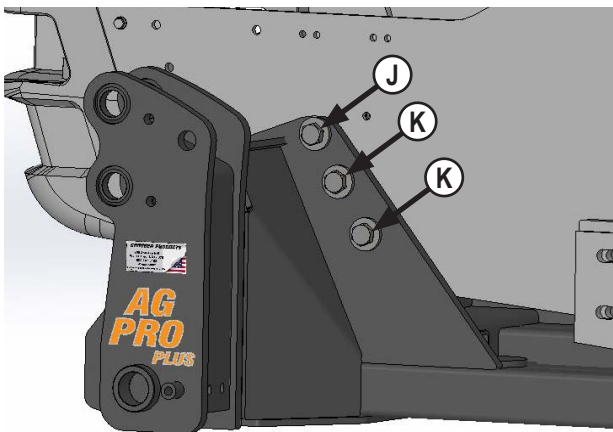

30. Using front undercarriage side holes as guides, drill 6 - 1" holes through side of tractor frame.

NOTE: When drilling, be aware of all parts behind material being drilled so that you do not mistakenly hit or puncture components on engine side of tractor frame.

NOTE: Add washers as shims between undercarriage and tractor frame to reduce any gap if necessary. Use washers until there is a gap of 1/16" or less. Do Not put all of shims on one side of undercarriage.

31. Install 1 - 1" x 3" bolts and 1 - 1" ID heavy washers through top hole on each side of undercarriage, shim washers and tractor frame (J).
32. Install 1 - 1" flat washers and 1 - 1" nuts on each of the previously installed bolts. Change 3" bolt to longer bolt if necessary.
33. Install 2 - 1" x 3-3/4" bolts and 2 - 1" ID heavy washers through bottom two holes on each side of undercarriage, shim washers and tractor frame (K).
34. Install 1 - 1" ID heavy washers and 1 - 1" nuts on each of the previously installed bolts.
35. Torque the side 1" bolts to 903 ft-lbs.

Hose Routing

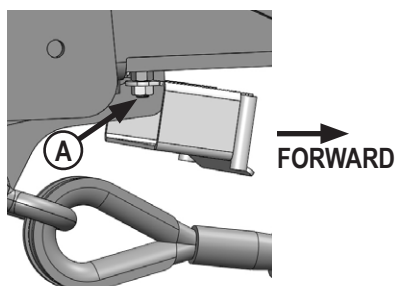

1. Gather and position hoses inside hose routing bracket. Raise rear hose routing bracket with hoses and attach to 20mm bolts located at front of rear tractor frame behind pivot area. Attach with 2 - 20mm nuts (A). Ensure lip of bracket is facing towards front of tractor.
2. Torque the 20mm nuts to 432 ft-lbs (J).

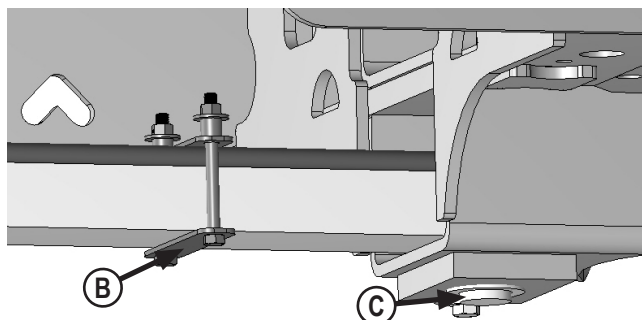

3. Position hoses on top of drawbar and secure with 4- hose holding plates, 4 - 1/2" x 5-1/2" or 6" bolts, and 4 - 1/2" nuts.
4. Place front holding plates (B) 12" from center of drawbar pin at front of drawbar (C).

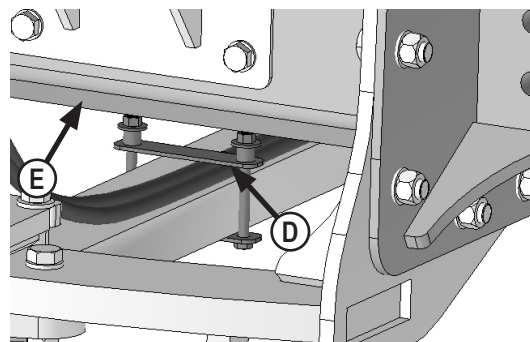

5. Place rear holding plates (D) half-way between rear axle and rear tractor frame (E).

NOTE: Before tightening any bolts, turn and articulate tractor to provide slack in hoses at pivot point.

NOTE: When tightening the 1/2" nuts, do not crush the hoses.

6. Tighten hardware on drawbar hose holding plates until plates are firmly against hoses without deforming hoses. Use 3/4" spacers and 1/2" washers on top plate if needed to provide enough thread to tighten.
7. Insert couplers in open SCV's at back of tractor.
8. Perform an articulation check to make sure hoses do not get pulled when fully articulated. Make adjustments and allow adequate slack if necessary.

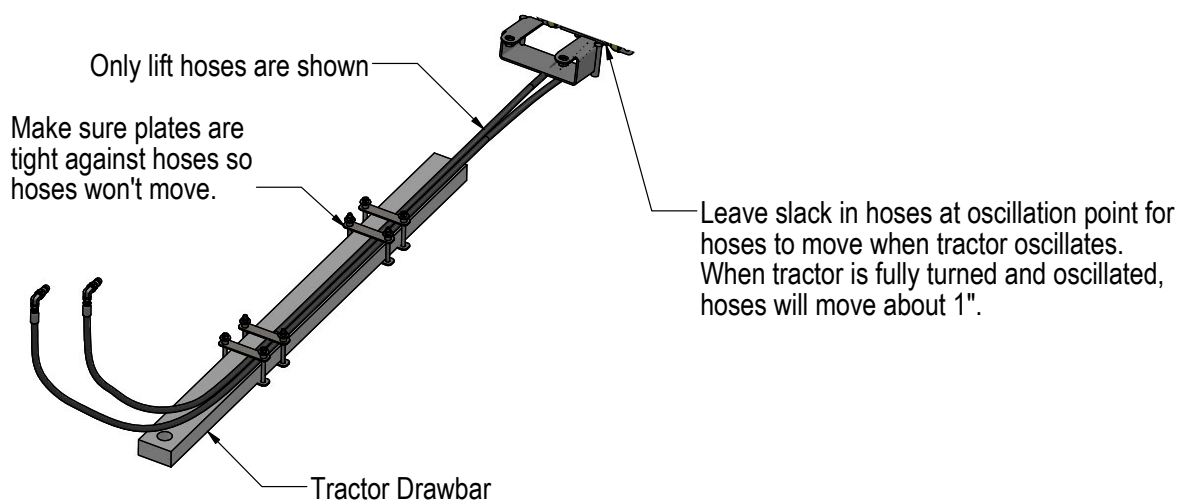

Assembling Lift Components

Refer to the Blade Owner's Manual & Parts Book for instructions on how to assemble the lift components.

Maintenance

1. After first 8 hours of use, re-torque all bolts.
2. Check all fasteners regularly to ensure proper operation of equipment.
3. Inspect all equipment for existing or potential damages every 10 hours or less.

ITEM NO.	QTY.	PART NO.	DESCRIPTION
1	8	16-1510	20mm x 2.5mm x 90mm Hex Bolt Gr 10.9
2	4	16-20124	1/2" X 1" Hex Bolt Gr 5 NC CZ
3	4	16-20562	1" X 3" Hex Bolt Gr 8 NC YZ
3A	2	16-20563	1" X 3-1/4" Hex Bolt Gr 8 NC YZ
4	4	16-20565	1" X 3-3/4" Hex Bolt Gr 8 NC YZ
5	1	27-18887	Grouser Name Plate Decal
6	1	27-40962	Warning Prop 65 Decal
7	2	27-40983	Ag Pro Decal
8	1	NA	Grouser Dozer Metal Serial Tag
9	1	44-40504	Plate, Cover
10	1	54-19900	STX, Quad, & TJ Narrow Frame UC Weld
11	5	57-20744	1/2" Flat Washer CZ
12	12	57-20749	1" Flat Washer CZ
13	2	57-20819	1" Flat Washer Heavy Duty Gr 8 (USS) YZ
14	10	57-3682	1.00" ID x 2.50" OD x .375" Heavy Washer
15	8	57-8836	7/8" x 2-1/2" x 1/2" Flat Washer
16	8	70-20599	1" Hex Nut Gr 8 NC CZ
17	1	70-20604	1/2" Hex Center Lock Nut Gr 5 NC CZ

Item 3A is used only if a longer bolt is needed.

Item 12 is used as shims between tractor frame and undercarriage. Only use if needed.

Note: See Page 5 for some hose routing parts not listed here.

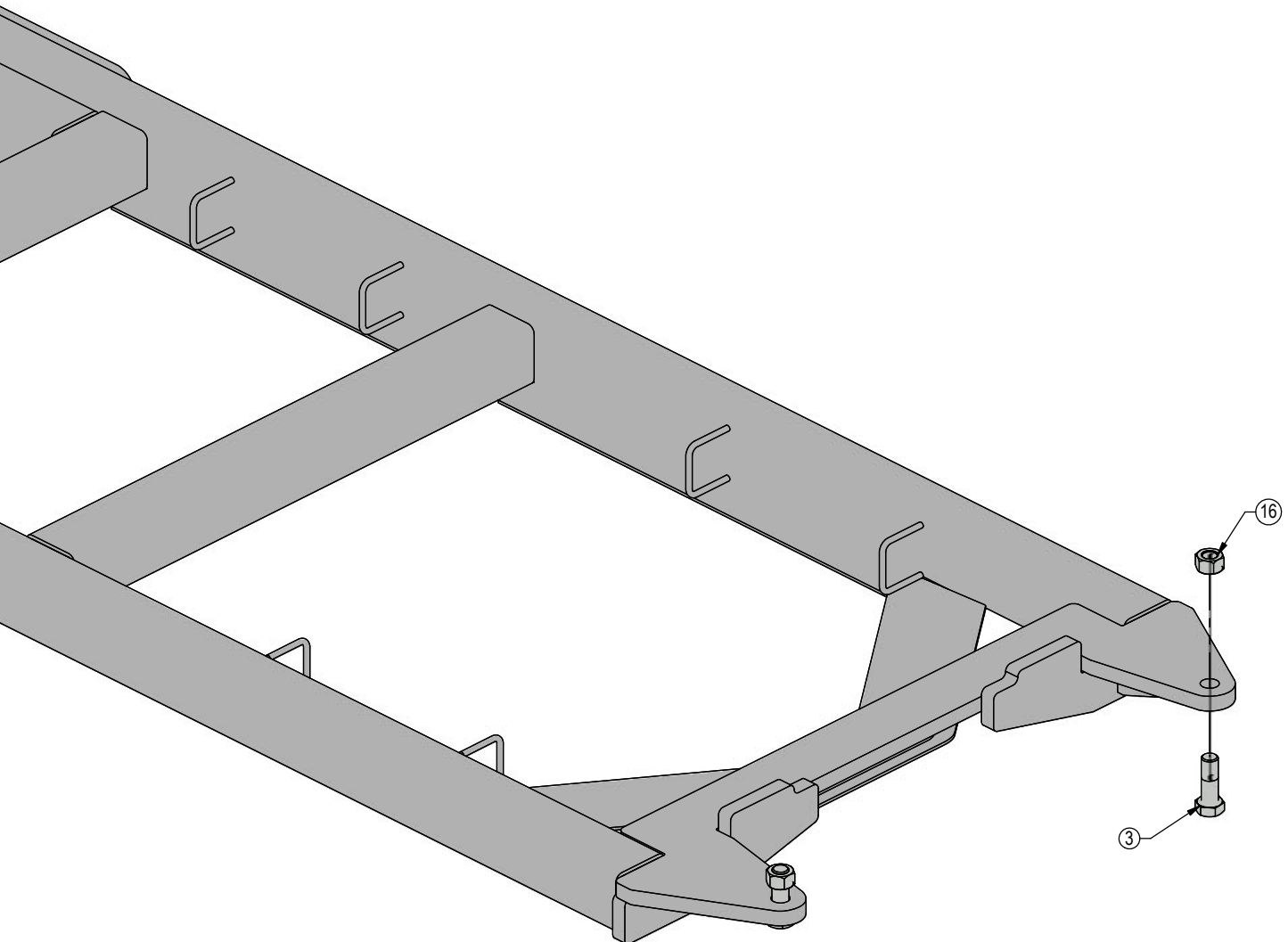

Quad - Welded Yoke

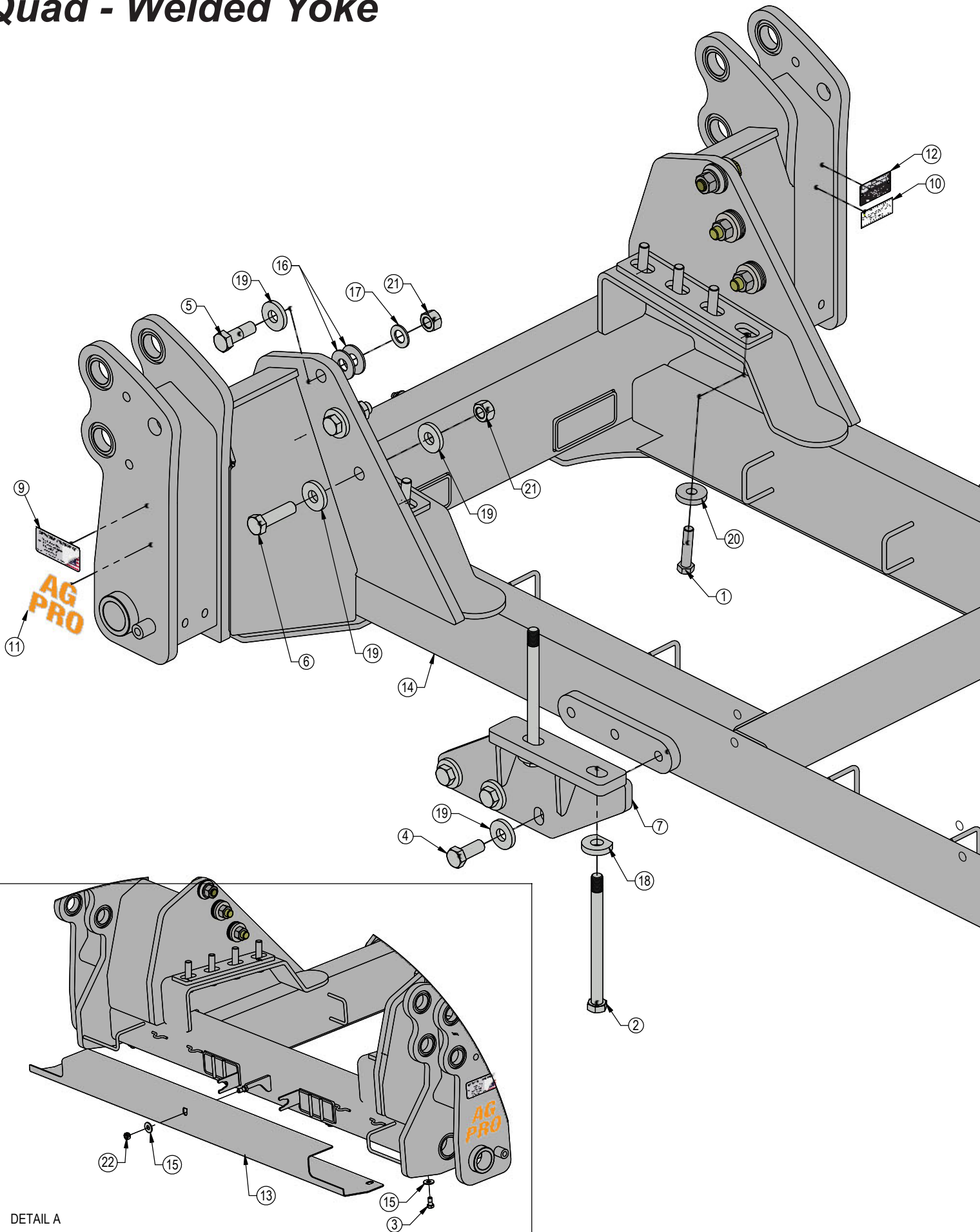

DETAIL A
SCALE 1 : 16

ITEM NO.	QTY.	PART NO.	DESCRIPTION
1	8	16-1510	20mm x 2.5mm x 90mm Hex Bolt Gr 10.9
2	4	16-1574	24mm x 3.0mm x 300mm Metric Hex Bolt Gr 10.9 Plated
3	4	16-20124	1/2" X 1" Hex Bolt Gr 5 NC CZ
4	6	16-20560	1" X 2-1/2" Hex Bolt Gr 8 NC YZ
5	4	16-20562	1" X 3" Hex Bolt Gr 8 NC YZ
5A	2	16-20563	1" X 3-1/4" Hex Bolt Gr 8 NC YZ
6	4	16-20565	1" X 3-3/4" Hex Bolt Gr 8 NC YZ
7	1	18-19920-L	Side Bracket, Welded Yoke
8	1	18-19920-R	Side Bracket, Welded Yoke
9	1	27-18887	Grouser Name Plate Decal
10	1	27-40962	Warning Prop 65 Decal
11	2	27-40983	Ag Pro Decal
12	1	NA	Grouser Dozer Metal Serial Tag
13	1	44-40504	Plate, Cover
14	1	54-19900R5	STX, Quad, & TJ Narrow Frame UC Weld
15	5	57-20744	1/2" Flat Washer CZ
16	12	57-20749	1" Flat Washer CZ
17	2	57-20819	1" Flat Washer Heavy Duty Gr 8 (USS) YZ
18	4	57-3098	1.05" ID x 2.50" OD - JD Axle Mount Washer
19	16	57-3682	1.00" ID x 2.50" OD x .375" Heavy Washer
20	8	57-8836	7/8" x 2-1/2" x 1/2" Flat Washer
21	8	70-20599	1" Hex Nut Gr 8 NC CZ
22	1	70-20604	1/2" Hex Center Lock Nut Gr 5 NC CZ

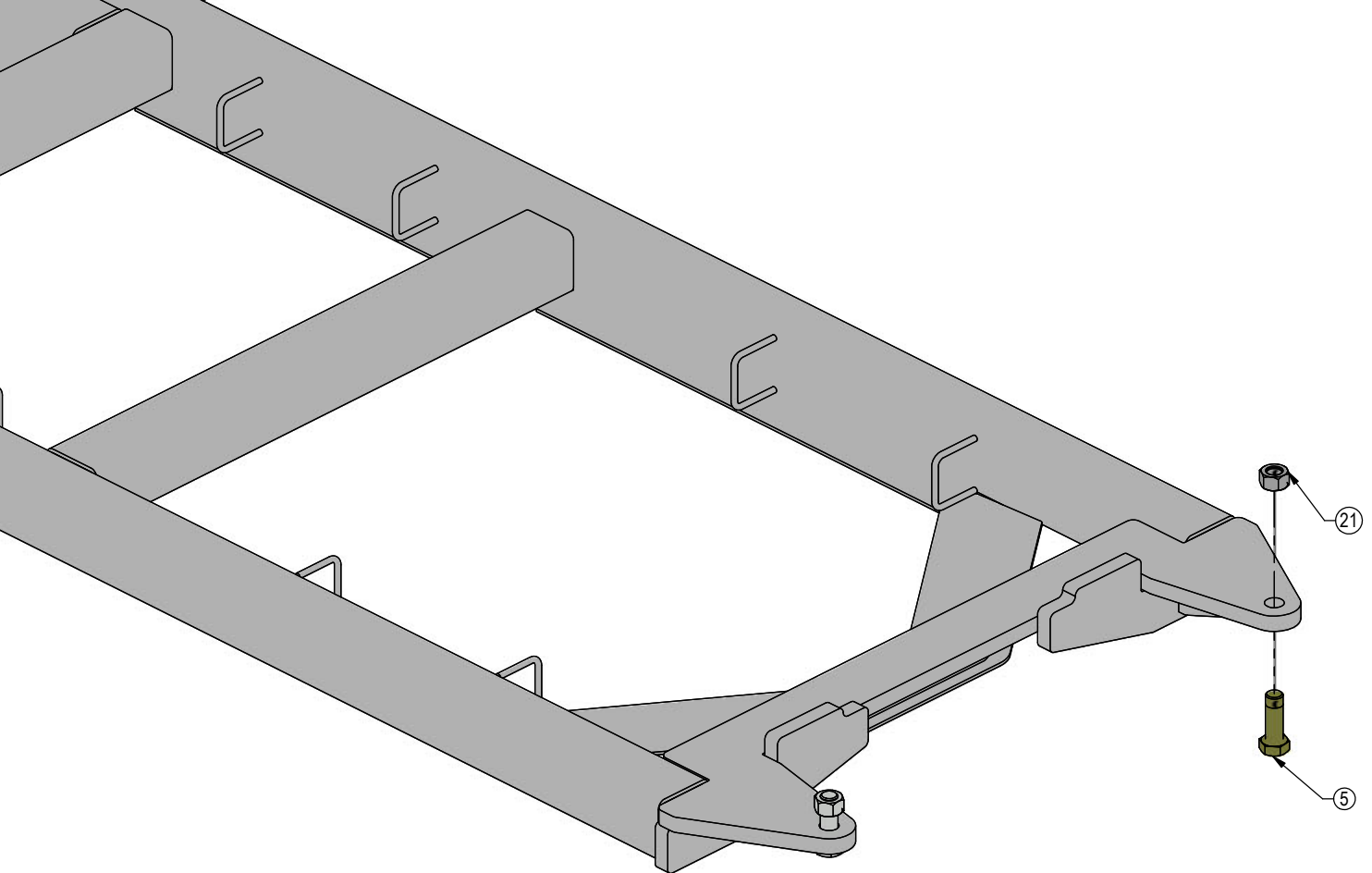
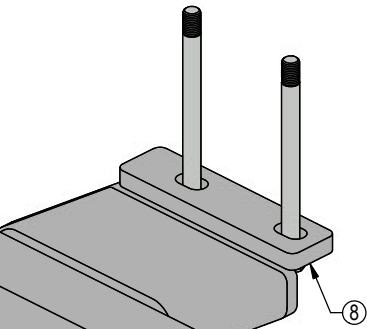

Item 5A is used only if a longer bolt is needed.

Item 16 is used as shims between tractor frame and undercarriage. Only use if needed.

Note: See Page 5 for some hose routing parts not listed here.

Quad - Cast Yoke

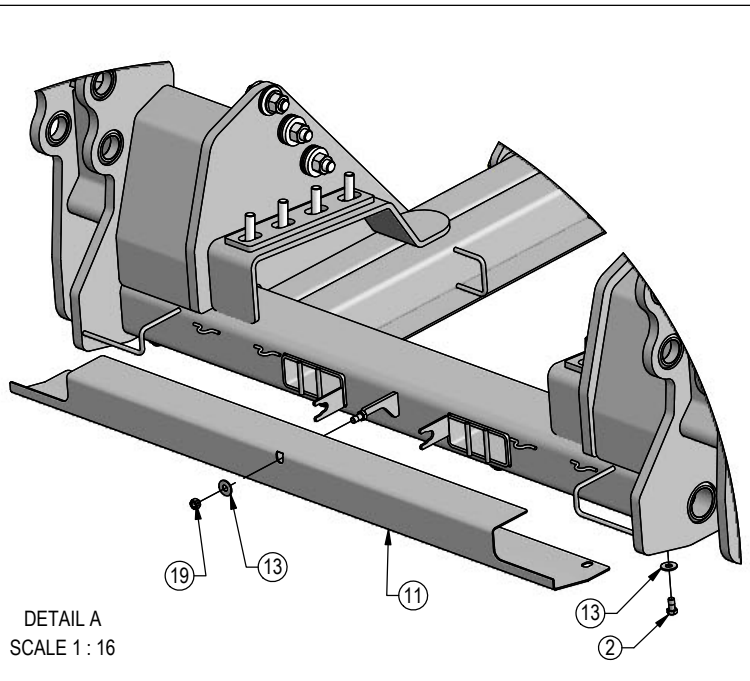
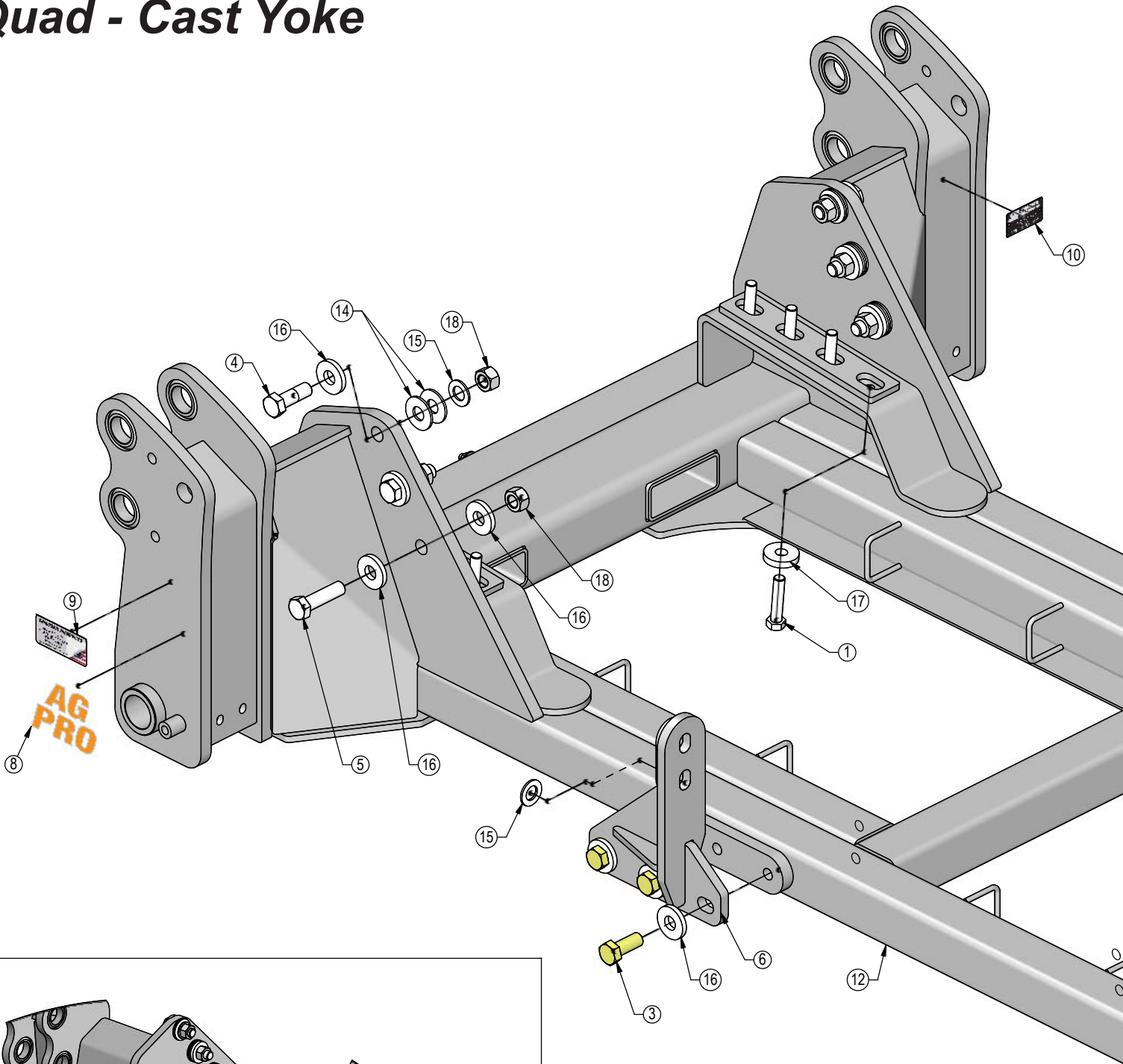

ITEM NO.	QTY.	PART NO.	DESCRIPTION
1	8	16-1510	20mm x 2.5mm x 90mm Hex Bolt Gr 10.9
2	4	16-20124	1/2" X 1" Hex Bolt Gr 5 NC CZ
3	6	16-20560	1" X 2-1/2" Hex Bolt Gr 8 NC YZ
4	4	16-20562	1" X 3" Hex Bolt Gr 8 NC YZ
4A	2	16-20563	1" X 3-1/4" Hex Bolt Gr 8 NC YZ
5	4	16-20565	1" X 3-3/4" Hex Bolt Gr 8 NC YZ
6	1	18-19926-L	Side Bracket, Cast Yoke
7	1	18-19926-R	Side Bracket, Cast Yoke
8	2	27-40983	Ag Pro Decal
9	1	27-18887	Grouser Name Plate Decal
10	1	NA	Grouser Dozer Metal Serial Tag
11	1	44-40504	Plate, Cover
12	1	54-19900R5	STX, Quad, & TJ Narrow Frame UC Weld
13	5	57-20744	1/2" Flat Washer CZ
14	12	57-20749	1" Flat Washer CZ
15	6	57-20819	1" Flat Washer Heavy Duty Gr 8 (USS) YZ
16	16	57-3682	1.00" ID x 2.50" OD x .375" Heavy Washer
17	8	57-8836	7/8" x 2-1/2" x 1/2" Flat Washer
18	8	70-20599	1" Hex Nut Gr 8 NC CZ
19	1	70-20604	1/2" Hex Center Lock Nut Gr 5 NC CZ

Item 4A is used only if a longer bolt is needed.

Item 14 is used as shims between tractor frame and undercarriage. Only use if needed.

Note: See Page 5 for some hose routing parts not listed here.

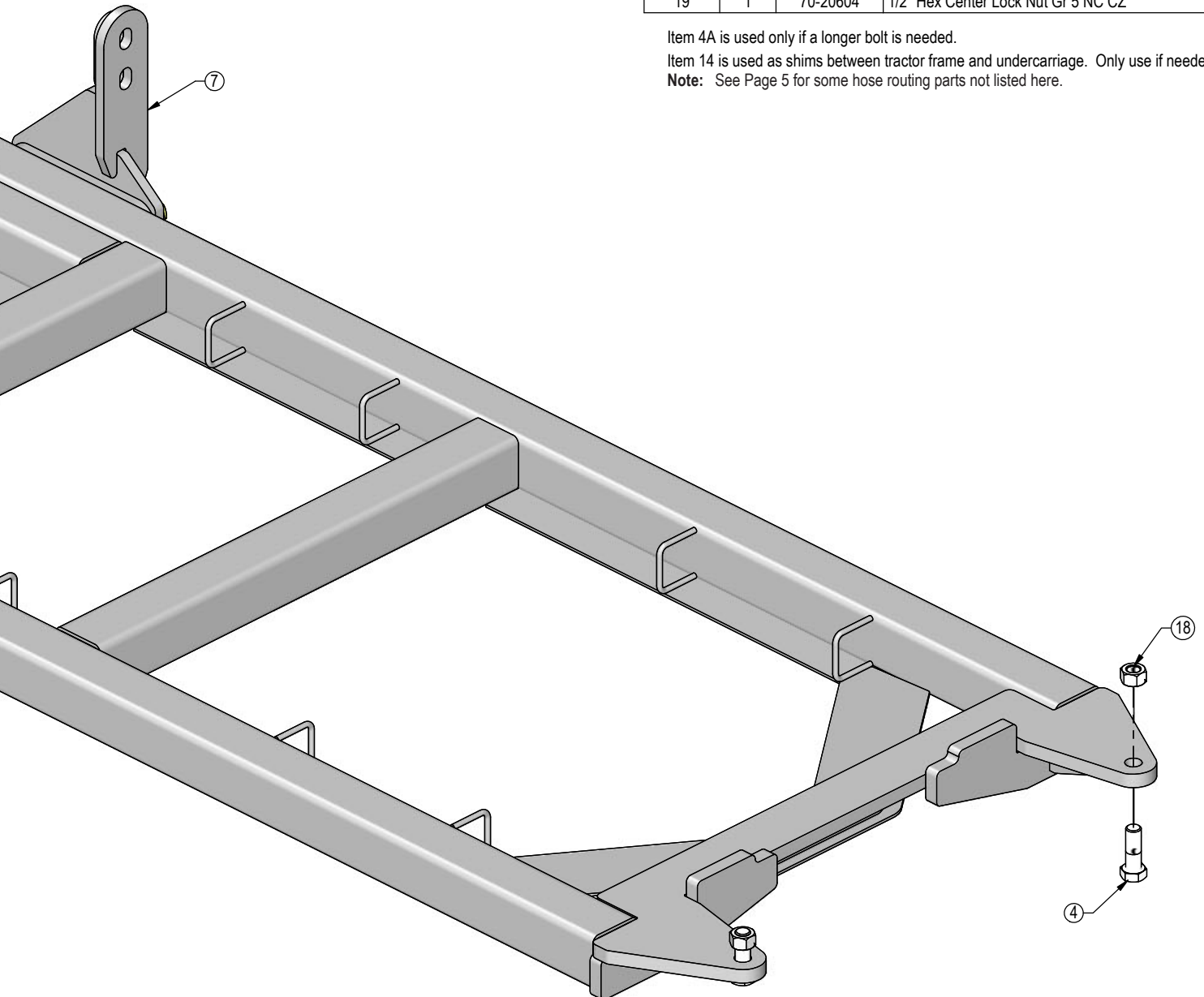

Improvements

Grouser Products Inc. is continually striving to improve its products. We reserve the right to change prices, specification, or equipment at any time without notice. We also reserve the right to make improvements or changes when it becomes practical and possible to do so without incurring any obligation to make changes or additions to the equipment sold previously.

Warranty

Grouser Products warrants to the original purchaser of each item that the product be free from defects in material and workmanship under normal use and service for a period of **two (2) years for Agriculture Series Blades and one (1) year for Heavy Duty Series from date of original retail delivery.**

The obligation of the consumer under this warranty:

1. To read the operators manual and to operate, lubricate, maintain and store equipment in accordance with the instructions listed in the operators manual.
2. To inspect equipment and if any part needs repair or replacement when continued use would cause damage or wear to other parts or safety.
3. All equipment or parts claimed to be defective in material or workmanship must be made available for inspection at the place of business of a dealer authorized to handle the equipment covered by this warranty, or, upon request by Grouser Products, shipped to the Grouser Products factory in West Fargo, North Dakota.

The obligation of the dealer under this warranty:

1. Complete warranty registration form and submit within 30 days of sale.
2. Contact Grouser Products for authorization prior to performing any warranty repairs or part replacement.
3. Complete warranty request form and submit with photos and supporting documentation.

The obligation of Grouser Products under this warranty:

1. Repair or replace, any equipment or parts, in the judgment of Grouser Products to be defective in material or workmanship.
2. Grouser Products will cover the cost of parts and ground shipping at dealer invoice only.
3. Grouser Products shall have no obligation to bear the cost of labor or transportation in connection with replacement or repair of any such defective parts.

This warranty does not cover:

1. Depreciation or damage caused by normal wear, accident, improper assembly, improper adjustments.
2. Improper maintenance including lack of proper lubrication, or improper use. Including loose bolts, nuts, or fitting due to over tightening or vibration after 20 hours of operation.
3. Repairs or alterations without authorization from a Grouser Products representative.
4. Grouser Products shall have no liability if the equipment has been altered or reworked without the written authorization of Grouser Products.

Grouser Products' parts, which are furnished under this warranty and properly installed, shall be warranted to the same extent as the original parts under this warranty if, and only if, such parts are found to be defective within the original warranty period covering the original equipment.

NO EMPLOYEE OR REPRESENTATIVE OF GROUSER PRODUCTS IS AUTHORIZED TO CHANGE THE WARRANTY IN ANY WAY OR GRANT ANY OTHER WARRANTY.

Contact Us

As always, if you have any questions about your system or other products made by Grouser, feel free to contact us.



755 2nd Ave NW - West Fargo, ND 58078
+1 701-282-7710 | info@grouser.com
www.grouser.com