

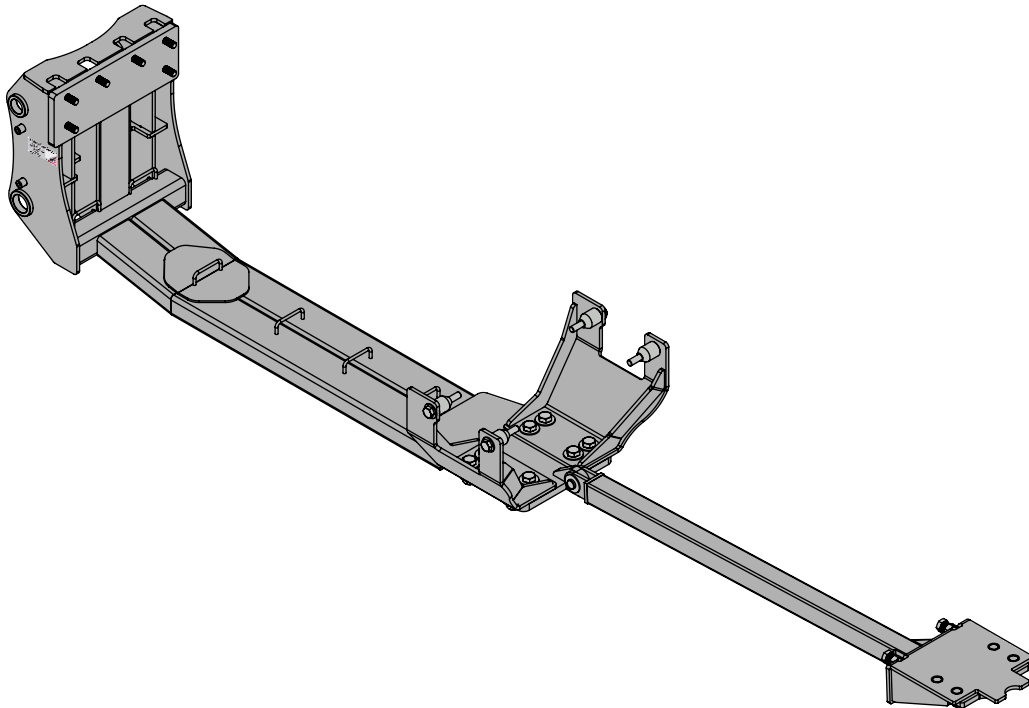

Agco DTB, Challenger MT600C,D & Massey 8600, 8700 Undercarriage Installation Instructions



For Models:

Agco: DT205B, DT225B, DT250B, DT275B

Challenger: MT645C&D, MT655C&D, MT665C&D, MT675C&D

Massey: 8650, 8660, 8670, 8680, 8690, 8727, 8730, 8732, 8735, 8737

Purchase Date
Serial Number
Model Number
Tractor Model
Dealer

To The Owner

This manual contains information concerning the installation of the undercarriage. You have purchased dependable, long lasting equipment, but only by proper care and operation can you expect to receive the performance and long service built into our products. Please have all operators read this manual carefully and keep the manual available for ready reference. If you have any questions or concerns, contact Grouser Products.

Caution:

- Always use caution when working around any equipment.
- Always wear safety glasses.
- Follow tractor manufacturer's safety guidelines when installing this product.
- Use paint where necessary to prevent rust.
- Do not modify or permit anyone else to modify or alter the equipment and its components without first consulting Grouser Products.

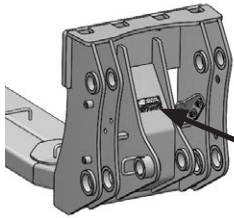

Serial Number Location

Note:

- When installing hardware, only finger tighten until all hardware is in place.
- A full diagram of the assembly with the full list of parts is on pages 4-5.
- Unstrap and remove any components that are attached for shipping.
- Read all instructions prior to performing installation.



To ensure the safety of those working under and around the machine, apply parking brake, remove key from ignition, and block tires before working on the machine.

Installation

1. Remove weights and weight carrier from front of tractor if necessary.

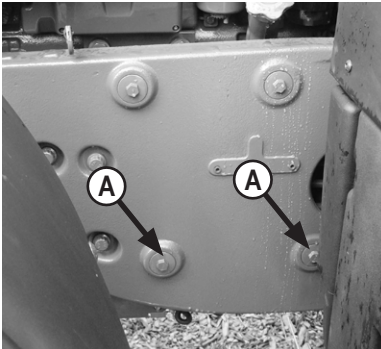

2. **Without** loader brackets, remove bottom 2 plugs from holes on each side of tractor behind front axle (A). Proceed with Step #4.
3. **With** loader brackets, remove bottom 2 bolts from each side of tractor behind front axle (A). Proceed with Step #4.

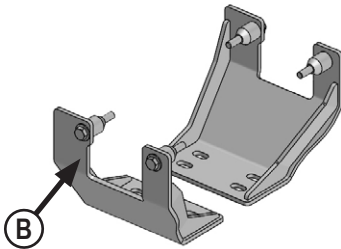

4. Attach side rails to tractor with 4 - 20mm x 130mm bolts and 4 - 3/4" flat washers (B) where plugs or bolts were removed from tractor. **Without** loader brackets, use supplied spacers between side rails and tractor frame.

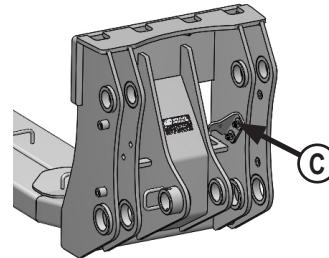

5. Remove hose clamp brackets (C) from front of undercarriage mount to gain access to front bolts.
6. Position the undercarriage under tractor and center on the frame of the tractor.

NOTE: When lifting the undercarriage, watch for any potential pinching of hoses or any other components to prevent damage.

7. Raise undercarriage until holes on undercarriage line up with front tractor frame holes.

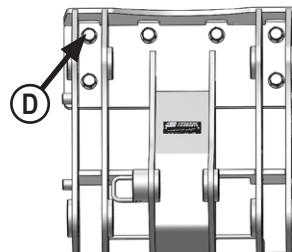

8. Attach front of undercarriage to front of tractor with 6 - 20mm x 70mm bolts and 6 - 3/4" hardened flat washers (D).

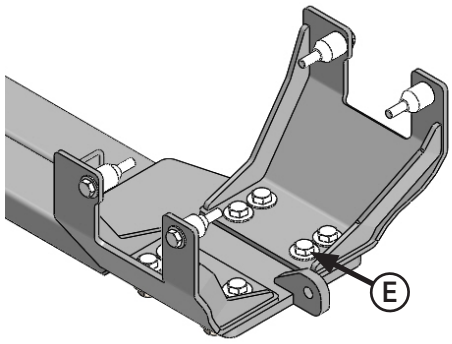

9. Attach rear of undercarriage to side rails with 8 - 1" x 3" bolts, 16 - 1" flat washers and 8 - 1" nuts (E).
10. Pull drawbar out to allow room for installing push pole.

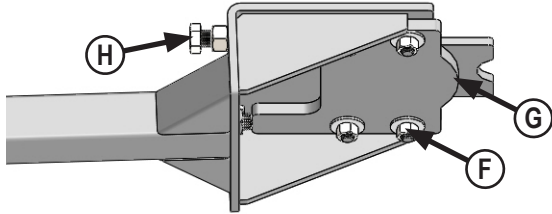

11. Attach push plate to rear of push pole with 4 - 3/4" flat washers and 4 - 3/4" nuts (F). The round edge of push plate towards open end of push pole (G).
12. Install 2 - 1" x 3" bolts and 2 - 1" nuts at rear of push pole (H). Screw bolts in a few turns. Bolts will be adjusted in a later step.
13. Raise rear of push pole and rest top plate on top of drawbar bracket.

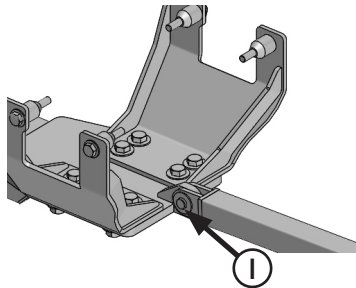

14. Attach front of push pole to rear of undercarriage with 1" pin, 2 - 1" washers and a cotter pin (I).
15. Torque front 20mm bolts (D) to 432 ft-lbs.
16. Torque side rail 20mm bolts (B) to 432 ft-lbs.
17. Torque 1" nuts attaching side rails to undercarriage (E) to 909 ft-lbs.

18. Evenly unscrew 1" bolts at rear of push pole to push rear plate tight against tractor casting. Torque 1" bolts to 90-95 ft lbs (H).
19. Tighten 1" nuts against push pole. The nuts lock bolts in place.
20. Torque bottom 3/4" nuts (F) to 257 ft-lbs.
21. Reattach the hose clamp bracket (C) that was removed in Step #5.
22. Torque 1/2" nuts (C) to 75 ft-lbs.

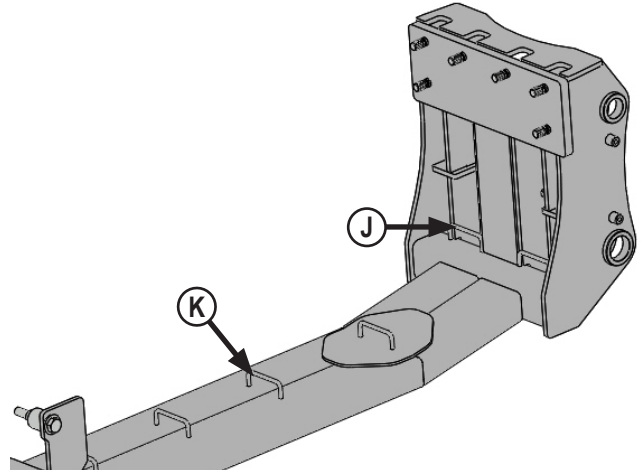

23. Route hoses through hose loops at front of undercarriage (J).
24. Continue to route the hoses through hose loops on undercarriage (K).
25. Route hoses to back of tractor and plug into open SCV's at rear of tractor.

Note: The installer is responsible to route hoses in a practical manner, to protect the hoses around sharp corners and moving objects, and secure hoses.

Warning: Fully oscillate the blade angle, tilt, steering, suspension and rear 3-point to check for adequate clearance.

The minimum clearance between any part on blade and front tires when blade is fully angled, should be 3". If more clearance is necessary between the blade and front tires, call Grouser Products.

Assembling Lift Components

1. Refer to the Blade Owner's Manual & Parts Book for instructions on how to assemble the lift components.

Maintenance

1. After first 8 hours of use, re-torque all bolts.
2. Check all fasteners regularly to ensure proper operation of equipment.
3. Inspect all equipment for existing or potential damages every 10 hours or less.

See Detail A for Front View

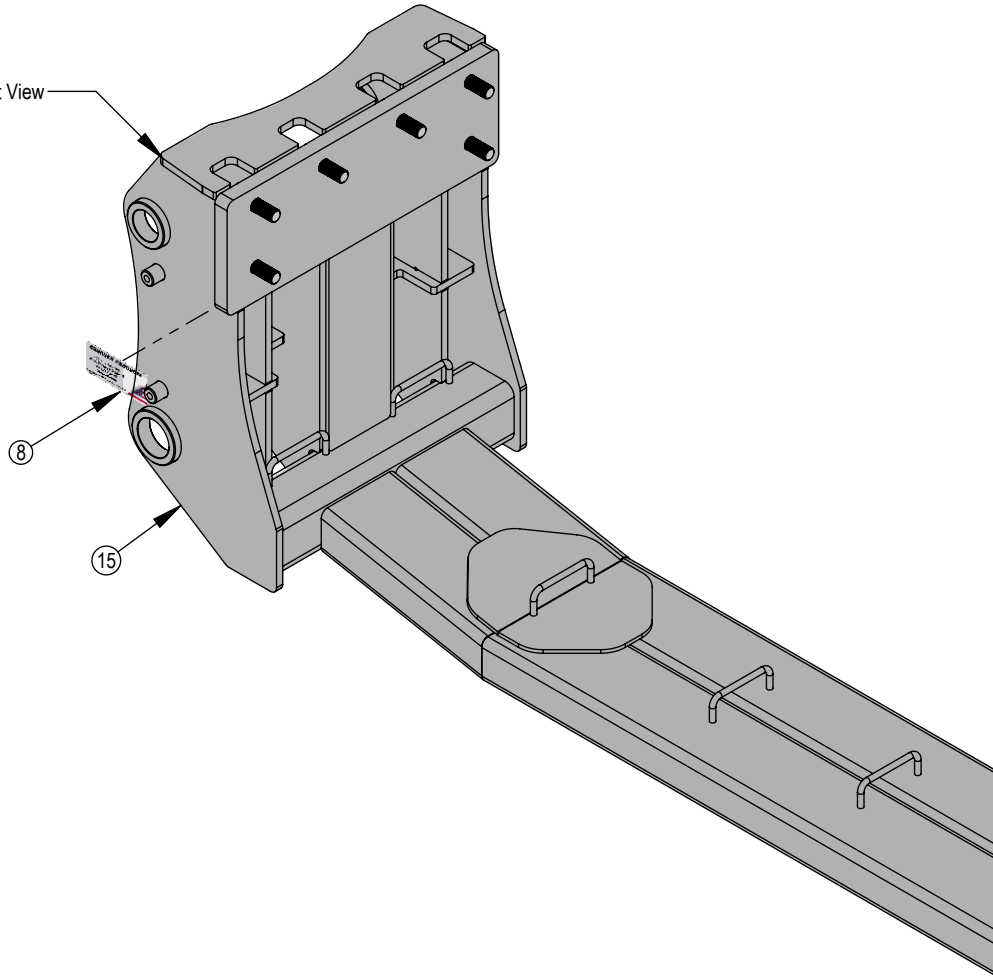

ITEM NO.	QTY.	PART NO.	DESCRIPTION
1	6	16-1876	20mm x 2.5mm x 70mm Hex Bolt Gr 10.9
2	10	16-20562	1" x 3" Hex Bolt Gr 8 NC
3	2	16-21126	1/2" x 1-1/2" Carriage Bolt Gr 5 NC
4	4	16-2490	20mm x 2.5mm x 130mm Metric Hex Bolt Gr 10.9
5	1	17-13895	Push Pole Weld
6	1	18-42691	Hose Bracket
7	4	19-13899	Spacer
8	1	27-18887	Grouser Name Plate Decal
9	1	NA	Grouser Dozer Metal Serial Tag
10	1	43-18463	1" x 2.75" Pin
11	1	43-18943	3/16" x 1-1/2" Cotter Pin
12	1	44-13896	Plate, Push
13	1	46-13885-L	Side Plate Weld
14	1	46-13885-R	Side Plate Weld
15	1	54-43085	Undercarriage Weld
16	2	57-20744	1/2" Flat Washer
17	8	57-20747	3/4" Flat Washer
18	2	57-20749	1" Flat Washer
19	6	57-20757	3/4" Flat Washer - 1-1/2" OD
20	16	57-20819	1" Flat Washer Heavy Duty Gr 8
21	10	70-20589	1" Hex Nut Gr 5 NC
22	2	70-20604	1/2" Center Lock Hex Nut
23	4	70-20607	3/4" Center Lock Hex Nut

DETAIL A

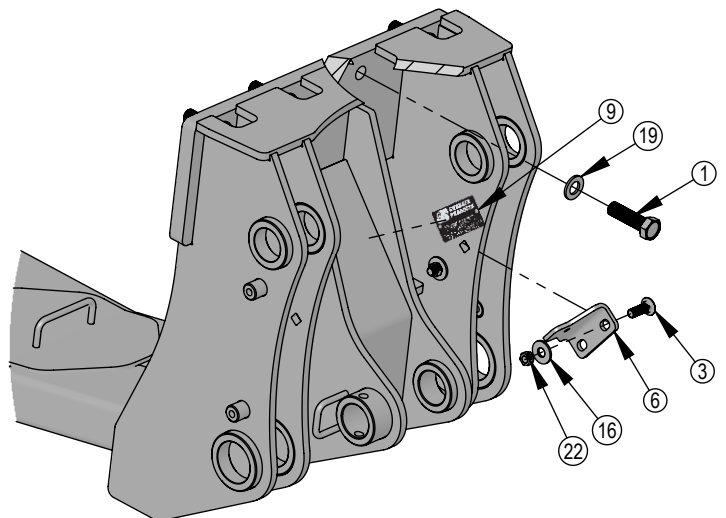

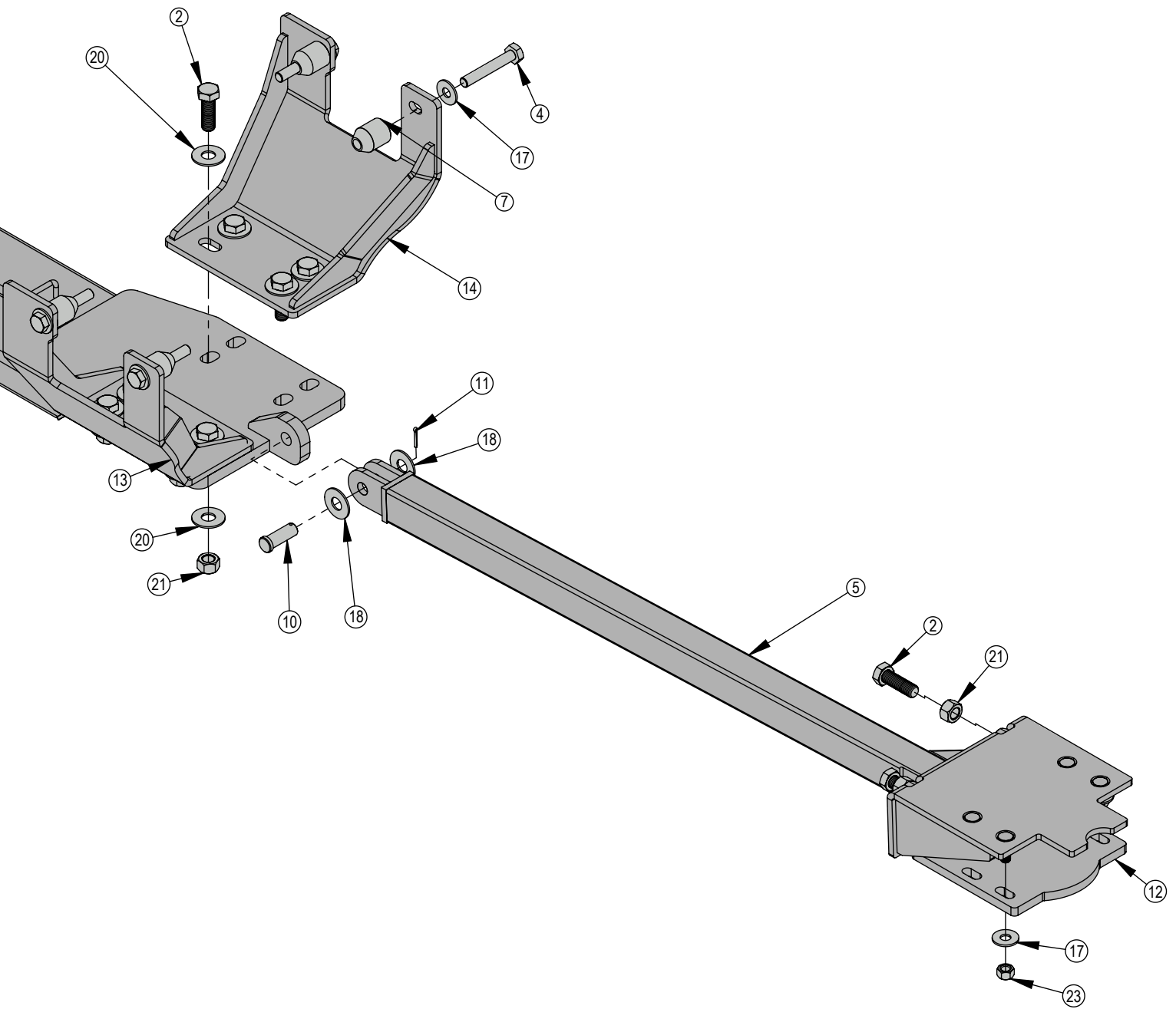

DWG. NO.: 43090-A

Notes

Notes

Improvements

Grouser Products Inc. is continually striving to improve its products. We reserve the right to change prices, specification, or equipment at any time without notice. We also reserve the right to make improvements or changes when it becomes practical and possible to do so without incurring any obligation to make changes or additions to the equipment sold previously.

Warranty

Grouser Products warrants to the original purchaser of each item that the product be free from defects in material and workmanship under normal use and service for a period of **two (2) years for Agriculture Series Blades and one (1) year for Heavy Duty Series from date of original retail delivery.**

The obligation of the consumer under this warranty:

1. To read the operators manual and to operate, lubricate, maintain and store equipment in accordance with the instructions listed in the operators manual.
2. To inspect equipment and if any part needs repair or replacement when continued use would cause damage or wear to other parts or safety.
3. All equipment or parts claimed to be defective in material or workmanship must be made available for inspection at the place of business of a dealer authorized to handle the equipment covered by this warranty, or, upon request by Grouser Products, shipped to the Grouser Products factory in West Fargo, North Dakota.

The obligation of the dealer under this warranty:

1. Complete warranty registration form and submit within 30 days of sale.
2. Contact Grouser Products for authorization prior to performing any warranty repairs or part replacement.
3. Complete warranty request form and submit with photos and supporting documentation.

The obligation of Grouser Products under this warranty:

1. Repair or replace, any equipment or parts, in the judgment of Grouser Products to be defective in material or workmanship.
2. Grouser Products will cover the cost of parts and ground shipping at dealer invoice only.
3. Grouser Products shall have no obligation to bear the cost of labor or transportation in connection with replacement or repair of any such defective parts.

This warranty does not cover:

1. Depreciation or damage caused by normal wear, accident, improper assembly, improper adjustments.
2. Improper maintenance including lack of proper lubrication, or improper use. Including loose bolts, nuts, or fitting due to over tightening or vibration after 20 hours of operation.
3. Repairs or alterations without authorization from a Grouser Products representative.
4. Grouser Products shall have no liability if the equipment has been altered or reworked without the written authorization of Grouser Products.

Grouser Products' parts, which are furnished under this warranty and properly installed, shall be warranted to the same extent as the original parts under this warranty if, and only if, such parts are found to be defective within the original warranty period covering the original equipment.

NO EMPLOYEE OR REPRESENTATIVE OF GROUSER PRODUCTS IS AUTHORIZED TO CHANGE THE WARRANTY IN ANY WAY OR GRANT ANY OTHER WARRANTY.

Contact Us

As always, if you have any questions about your system or other products made by Grouser, feel free to contact us.



755 2nd Ave NW - West Fargo, ND 58078
+1 701-282-7710 | info@grouser.com
www.grouser.com